

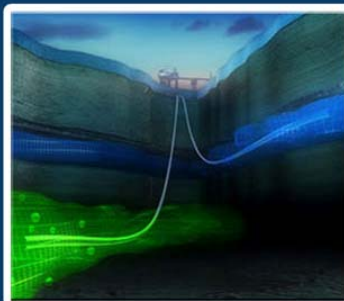

Carbon Sequestration Leadership Forum Technology Roadmap

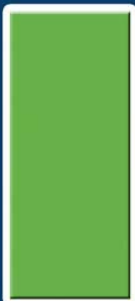

A Global Response to the Challenge of Climate Change

Cover Photo Credits:

Left to Right:

IEA GHG Weyburn-Midale CO₂ Monitoring and Storage Project, Photo courtesy of Petroleum Technology Research Centre

CO₂STORE, Photo courtesy of Alligator film/BUG/StatoilHydro

Geologic CO₂ Storage Assurance at In Salah, Algeria, Photo courtesy of BP

TABLE OF CONTENTS

MODULE 0: INTRODUCTION	1
0.1. Context	1
0.2. The Purpose of the CSLF Technology Roadmap.....	1
0.3. Structure of this Technology Roadmap	1
MODULE 1: CURRENT STATUS OF CO₂ CAPTURE AND STORAGE TECHNOLOGY	3
1.1. Preamble - Sources of CO ₂	3
1.2. Capture of CO ₂	4
1.3. CO ₂ Transmission/Transport	8
1.4. Storage of CO ₂	9
1.5. Uses for CO ₂	14
1.6. The Potential for CO ₂ Storage	16
MODULE 2: ONGOING ACTIVITIES IN CO₂ CAPTURE AND STORAGE	21
2.1. Introduction.....	21
2.2. CSLF Activities and Achievements	22
2.3. Commercial Scale CCS Project Activities	23
2.4. Demonstration and Research Activities.....	26
2.5. R&D Components in CSLF Member Countries.....	27
MODULE 3: GAP IDENTIFICATION	33
3.1. The Need for New/Improved Technology.....	33
3.2. Technology Gaps.....	34
3.3. Summary of Key Technology Needs and Gaps	40
MODULE 4: TECHNOLOGY ROADMAP	42
4.1. The Role of the CSLF	42
4.2. Achieving Widespread CCS Deployment	42
4.3. CSLF Actions	44
4.4. Summary.....	46
REFERENCES	47
GLOSSARY OF ACRONYMS, ABBREVIATIONS, AND UNITS	50

TABLE OF FIGURES

Figure 1.	World emissions flow chart.....	3
Figure 2.	Coal-fired power station with post-combustion capture of CO₂	5
Figure 3.	Photo montage of a 2x800 MW UK coal-fired power station with capture – shown behind the coal stockpiles	5
Figure 4.	Coal-fired Integrated Gasification Combined Cycle (IGCC) process with pre-combustion capture of CO₂	6
Figure 5.	Range of CO₂ transport costs for onshore and offshore pipelines per 250 km	9
Figure 6.	Geological options for CO₂ storage	10
Figure 7.	The theoretical global storage capacity of CO₂.....	16
Figure 8.	Estimates of CO₂ storage costs.....	17
Figure 9.	The conceptual costs associated with CO₂ capture for power stations	18
Figure 10.	Power station generation efficiencies with and without the capture of CO₂.....	19
Figure 11.	A summary of the CO₂ capture costs for new power stations based on current technology	19
Figure 12.	A comparison of the total cost of CCS for different power station types with a 500MW unit operating with 85% capacity factor	20
Figure 13.	Commercial and demonstration CCS projects announced or commenced in or before 2004.....	21
Figure 14.	Commercial and demonstration CCS projects either announced or commenced before 2009	22
Figure 15.	2004 CSLF Technology Roadmap.....	22
Figure 16.	2009 CSLF Technology Roadmap.....	43

MODULE 0: INTRODUCTION

0.1. Context

The first Carbon Sequestration Leadership Forum (CSLF) Technology Roadmap was developed in 2004 to identify promising directions for research in carbon dioxide (CO₂) capture and storage (CCS). Since this time, there has been rapid growth in interest and the application of CO₂ capture and storage technology around the world. There is a growing realisation that CCS is one of a number of measures to address CO₂ emissions and that without CCS, it will be extremely difficult, if not impossible, to reduce CO₂ emissions to the levels needed to mitigate climate change effects.

This updated Technology Roadmap takes account of the significant CCS developments that have occurred during 2004 to early 2009 and identifies key knowledge gaps and areas where further research should be undertaken.

Updates will be made on a regular basis so that the Technology Roadmap remains a living document and reference point for future carbon capture and storage technology development and deployment.

0.2. The Purpose of the CSLF Technology Roadmap

This Technology Roadmap is intended to provide a pathway toward the commercial deployment of integrated CO₂ capture, transport, and storage technologies. Specifically, the Technology Roadmap focuses on:

- Achieving commercial viability and integration of CO₂ capture, transport, and storage;
- Developing an understanding of global storage potential, including matching CO₂ sources with potential storage sites and infrastructure needs;
- Addressing risk factors to increase confidence in the long-term effectiveness of CO₂ storage; and
- Building technical competence and confidence through sharing information and experience from demonstrations.

The Technology Roadmap aims to provide guidance to the CSLF and its Members by:

- Describing possible routes to meet future integrated CO₂ capture, transport, and storage needs; and
- Indicating areas where the CSLF can make a difference and add value through international collaborative effort.

The Technology Roadmap will also assist the CSLF in achieving its mission to facilitate the development and deployment of CCS technologies via collaborative efforts that address key technical, economic, and environmental obstacles. Information concerning the CSLF, its Charter, and its activities can be found at www.cslforum.org.

0.3. Structure of this Technology Roadmap

This Technology Roadmap comprises four modules. The first module briefly describes the current status of CO₂ capture and storage technology. The second module outlines ongoing activities, while the third module identifies technology needs and gaps that should be addressed over the next decade and beyond. The final module describes various approaches toward integrated CO₂ capture, transport, and storage and indicates achievable milestones.

MODULE 1: CURRENT STATUS OF CO₂ CAPTURE AND STORAGE TECHNOLOGY

1.1. Preamble – Sources of CO₂

Anthropogenic CO₂ is emitted into the atmosphere from:

- The combustion of fossil fuels for electricity generation;
- Industrial processes such as iron and steelmaking and cement production;
- Chemical and petrochemical processing, such as hydrogen and ammonia production;
- Natural gas processing;
- The commercial and residential sectors that use fossil fuels for heating;
- Agricultural sources; and
- Automobiles and other mobile sources.

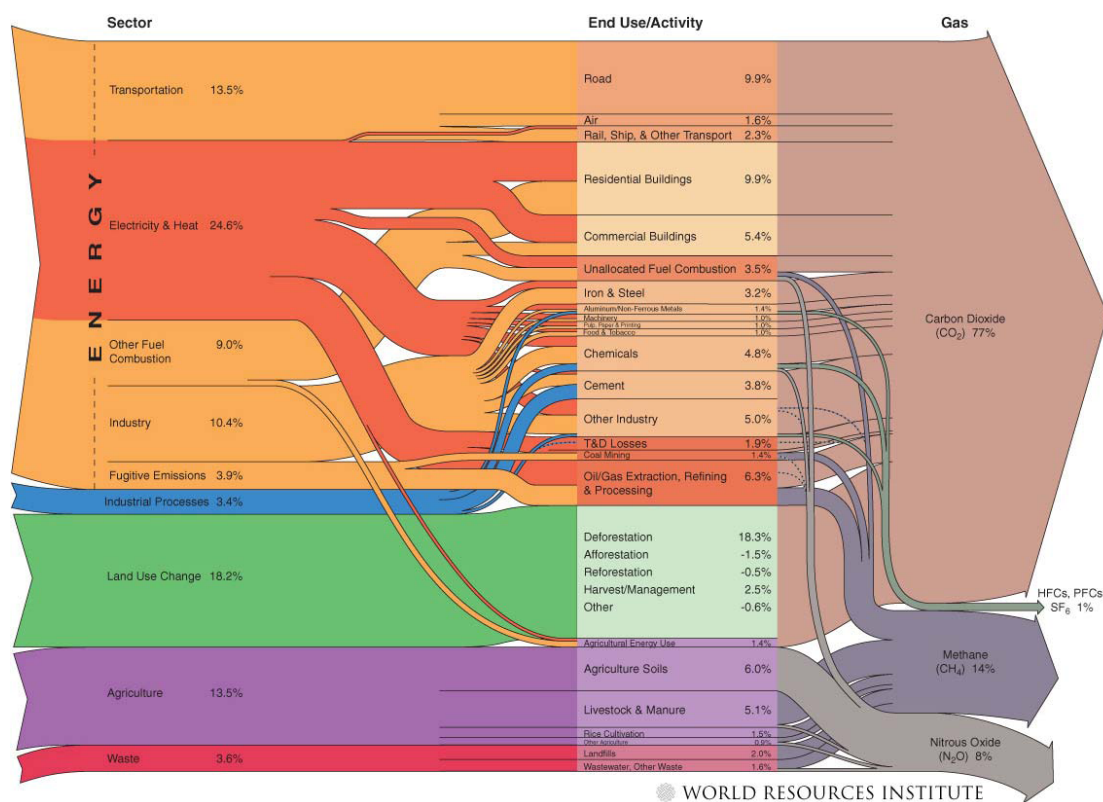

Figure 1. World emissions flow chart (World Resources Institute, 2005)

Due to the relative scale of emissions from stationary energy production there is an emphasis on power station emissions, although other emission sources from the energy and petrochemical industries, and industrial and transport applications are considered in the document.

To appreciate the volumes of CO₂ generated, a typical 500 megawatt (MW_e) coal-fired power station will emit about 400 tonnes of CO₂ per hour while a modern natural gas-fired combined cycle (NGCC) plant of the same size will emit about 180 tonnes per hour of CO₂ in flue gases. The respective CO₂ concentrations in flues gases are about 14% (by volume) for a coal-fired plant and 4% CO₂ for an NGCC plant. By comparison, the concentration of CO₂ in the flue gas of a cement kiln can be up to 33% by volume.

As seen in Figure 1 for global emissions, stationary energy/electricity generation from fossil fuels is responsible for just more than one-third of all CO₂ emissions. The emissions from other, large industrial sources, including iron and steelmaking, natural gas processing, petroleum refining, petrochemical processing, and cement production, amount to about 25% of the global total. As the CO₂ emitted from such processes is typically contained in a few large process streams, there is good potential to capture CO₂ from these processes as well. The high CO₂ concentrations of some of these streams, such as in natural gas processing and clinker production in cement making, may provide ideal opportunities for early application of CO₂ capture technology.

The global iron and steel industry is assessing carbon capture in the iron ore reduction process (principally the blast furnace and electric arc furnace routes) as one of a number of pathways for a low carbon future. The European Ultra Low Carbon Dioxide Steelmaking program (ULCOS http://www.ulcos.org/en/about_ulcos/home.php) is one such initiative that includes CCS as an element of technological developments.

The remaining anthropogenic CO₂ emissions are associated with transportation and commercial and residential sources. These are characterised by their small volume (individually) and the fact that, in the case of transportation, the sources are mobile. Capture of CO₂ from such sources is likely to be difficult and expensive, storage presents major logistical challenges, and collection and transportation of CO₂ from many small sources would suffer from small scale economic distortions. A much more attractive approach for tackling emissions from distributed energy users is to use a zero-carbon energy carrier, such as electricity, hydrogen, or heat.

CO₂ capture is, at present, both costly and energy intensive. For optimal containment and risk-related reasons, it is necessary to separate the CO₂ from the flue gas so that concentrated CO₂ is available for storage. Cost depends on many variables including the type and size of plant and the type of fuel used. Currently, the addition of CO₂ capture can add 50-100% (or more) to the investment cost of a new power station (OECD/IEA, 2008).

CO₂ capture systems are categorised as post-combustion capture, pre-combustion capture, and oxyfuel combustion.

1.2. Capture of CO₂

1.2.1. Post-combustion Capture

Post-combustion capture refers to separation of CO₂ from flue gas after the combustion process is complete. The established technique at present is to scrub the flue gas with an amine solution (alkanolamines, 1.2.4.1 below). The amine-CO₂ complex formed in the scrubber is then decomposed by heat to release high purity CO₂ and the regenerated amine is recycled to the scrubber. Figure 2 is a simplified diagram of a coal-fired power station with post-combustion capture of CO₂.

Post-combustion capture is applicable to coal-fired power stations but additional measures, such as desulphurisation, will prevent the impurities in the flue gas from contaminating the CO₂ capture solvent. Two challenges for post-combustion capture are the large volumes of gas, which must be handled, requiring large-scale equipment and high capital costs, and the amount of additional energy needed to operate the process. The scale of CO₂ capture equipment needed and the consequent space requirements are illustrated in Figure 2.

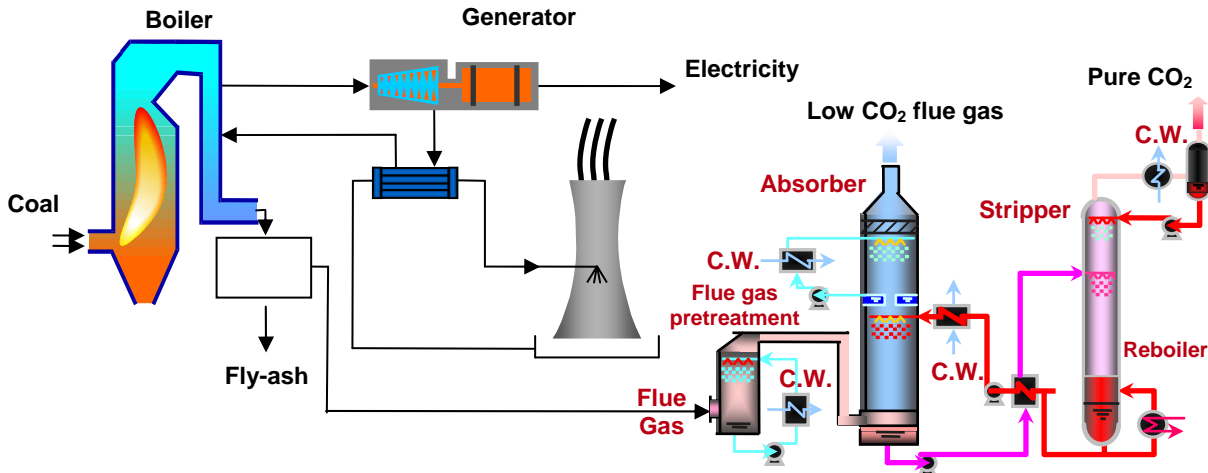

Figure 2. Coal-fired power station with post-combustion capture of CO₂ (courtesy of the Commonwealth Scientific and Industrial Research Organisation)



Figure 3. Photo montage of a 2x800 MW UK coal-fired power station with capture – shown behind the coal stockpiles (sourced from Imperial College, London and RWE Group)

1.2.2. Pre-combustion Capture

Pre-combustion capture increases the CO₂ concentration of the flue stream, requiring smaller equipment size and different solvents with lower regeneration energy requirements. The fuel is first partially reacted at high pressure with oxygen or air and, in some cases, steam, to produce carbon monoxide (CO) and hydrogen (H₂). The CO is reacted with steam in a catalytic shift reactor to produce CO₂ and additional H₂. The CO₂ is then separated and, for electricity generation, the H₂ is used as fuel in a combined cycle plant (see Figure 4). Although pre-combustion capture involves a more radical change to power station design, most elements of the technology are already well

proven in other industrial processes. One of the novel aspects is that the fuel from the CO₂ capture step is primarily H₂. While it is expected that pure H₂ (possibly diluted with nitrogen [N₂]) can be burned in an existing gas turbine with little modification, this technology has not been demonstrated, although turbine testing has been carried out by manufacturers. In other industrial applications, pre-combustion has been identified as a technology for residual liquid-petroleum fuel conversion where H₂, heat and power can be produced in addition to the CO₂ that needs to be captured.

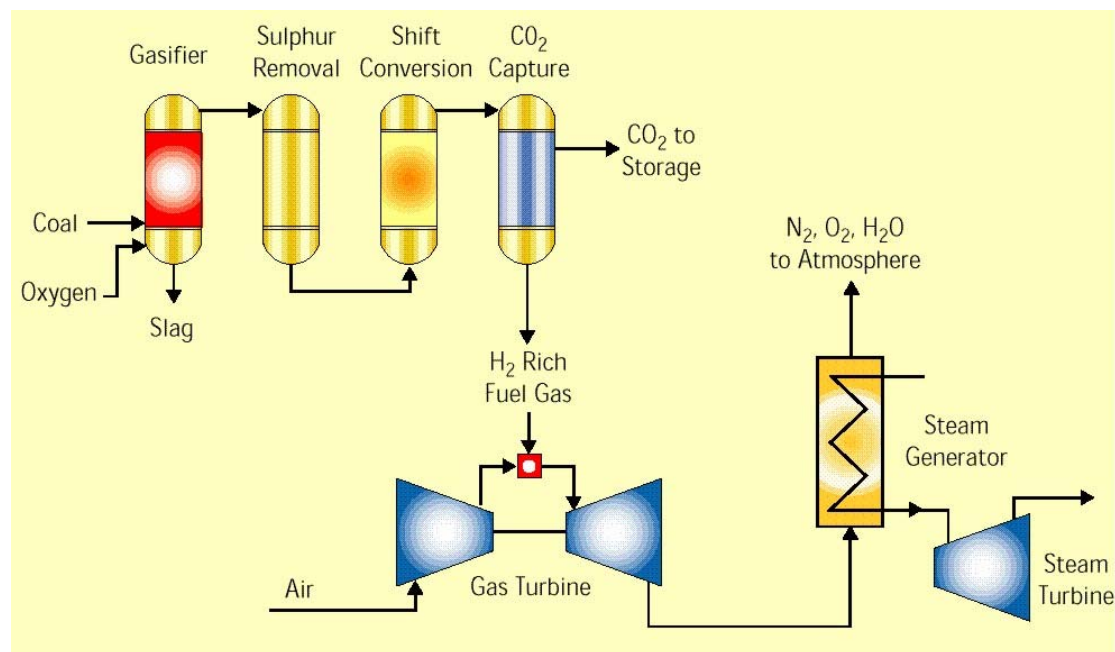

Figure 4. Coal-fired Integrated Gasification Combined Cycle (IGCC) process with pre-combustion capture of CO₂ (courtesy of the IEA Greenhouse Gas R&D Programme)

1.2.3. Oxyfuel Combustion

The concentration of CO₂ in flue gas can be increased by using pure or enriched oxygen (O₂) instead of air for combustion, either in a boiler or gas turbine. The O₂ would be produced by cryogenic air separation, which is already used on a large scale industrially, and the CO₂-rich flue gas would be recycled to the combustor to avoid the excessively high flame temperature associated with combustion in pure O₂. The advantage of oxyfuel combustion is that the flue gas contains a high concentration of CO₂, so the CO₂ separation stage is simplified. The primary disadvantage of oxyfuel combustion is that cryogenic O₂ is expensive, both in capital cost and energy consumption. Oxyfuel combustion for power generation has so far only been demonstrated on a small scale (up to about 30 MW_{th}).

1.2.4. Type of Capture Technology

Some of the most widely used CO₂ separation and capture technologies are described below.

1.2.4.1. Chemical Solvent Scrubbing

The most common chemical solvents used for CO₂ capture from low pressure flue gas are alkanolamines. Alkanolamines are commonly used in post combustion capture applications. The CO₂ reacts with the solvent in an absorption vessel. The CO₂-rich solvent from the absorber is passed into a stripping column where it is heated with steam to reverse the CO₂ absorption reaction.

CO₂ released in the stripper is compressed for transport and storage and the CO₂-free solvent is recycled to the absorption stage.

Amine scrubbing technology has been used for greater than 60 years in the refining and chemical industries for removal of hydrogen sulphide (H₂S) and CO₂ from reducing gases. Only a few facilities use amines to capture CO₂ from oxidising gases such as flue gas.

1.2.4.2. Physical Solvent Scrubbing

The conditions for CO₂ separation in pre-combustion capture processes are quite different from those in post-combustion capture. For example, the feed to the CO₂ capture unit in an integrated gasification combined cycle (IGCC) process, located upstream of the gas turbine, would have a CO₂ concentration of about 35–40% and a total pressure of 20 bar or more. Under these pre-combustion conditions, physical solvents that result in a lower regeneration energy consumption through (for example) a lowering of the stripper pressure could be advantageous.

1.2.4.3. Adsorption

Certain high surface area solids, such as zeolites and activated carbon, can be used to separate CO₂ from gas mixtures by physical adsorption in a cyclic process. Two or more fixed beds are used with adsorption occurring in one bed whilst the second is being regenerated. Pressure swing adsorption (PSA) achieves regeneration by reducing pressure, while temperature swing adsorption (TSA) regenerates the adsorbent by raising its temperature. Electric swing adsorption (ESA), which is not yet commercially available, regenerates the adsorbent by passing a low-voltage electric current through it. PSA and TSA are used to some extent in hydrogen production and in removal of CO₂ from natural gas but adsorption generally are not considered attractive for large-scale separation of CO₂ from flue gas because of low capacity and low CO₂ selectivity.

1.2.4.4. Membranes

Gas separation membranes such as porous inorganics, nonporous metals (e.g., palladium), polymers, and zeolites can be used to separate one component of a gas mixture from the rest. Many membranes cannot achieve the high degrees of separation needed in a single pass, so multiple stages and/or stream recycling are necessary. This leads to increased complexity, energy consumption, and costs.

Solvent-assisted membranes combine a membrane with the selective absorption of an amine, improving on both. This concept has been subject to long-term tests in a commercial test facility. Development of a membrane, capable of separating oxygen (O₂) and N₂ in air could play an important indirect role in CO₂ capture. Lower cost O₂ would be important in technologies involving coal gasification and in oxyfuel combustion. Much development and scale-up is required before membranes could be used on a large scale for capture of CO₂ in power stations.

1.2.4.5. Cryogenics

CO₂ can be separated from other gases by cooling and condensation. While cryogenic separation is now used commercially for purification of CO₂ from streams having high CO₂ concentrations (typically >90%), it is not used for more dilute CO₂ streams because of high-energy requirements. In addition, components such as water must be removed before the gas stream is cooled to avoid freezing and blocking flow lines.

1.2.4.6. Other Capture Processes

One radical but attractive technology is chemical looping combustion, in which direct contact between the fuel and combustion air is avoided by using a metal oxide to transfer oxygen to the fuel in a two-stage process. In the first reactor, the fuel is oxidised by reacting with a solid metal oxide,

producing a mixture of CO₂ and H₂O. The reduced solid is then transported to a second reactor where it is re-oxidised using air. Efficiencies comparable to those of other natural gas power generation options with CO₂ capture have been estimated. The major issue is development of materials able to withstand long-term chemical cycling.

The Effect of Fuel Type

The presence of fuel contaminants and specific combustion products impose additional constraints on the choice and operation of CO₂ control technology. With coal-fired systems, particulates can erode turbine blades in IGCC plants, contaminate solvents and foul heat exchangers in absorption processes, and foul membranes or sorbents in the new capture processes. Sulphur and nitrogen compounds must also be reduced to low levels before CO₂ capture because these impurities tend to react with amines to form heat stable salts, and may interact with membrane materials or sorbents to reduce the separation or capture efficiency. In contrast, natural gas and its combustion products are much more benign and tend to create fewer problems for all potential CO₂ capture options. Current work on “ultra-clean coal” products aims to address impurity and particulate issues so that coal-water mixtures can be used directly in reciprocating and turbine power generation systems.

Retrofit Application

Repowering of existing coal-fired power stations has produced extended lifetimes and, in some cases, substantially improved efficiencies. There is potential for CO₂ capture to be retrofitted to existing plants as a component of a repowering project, particularly as plant downtime and major works would be required during repowering. This potential, however, may be limited by physical site conditions and proximity to CO₂ transport facilities and storage sites. Taking into account capital cost, loss in power station efficiency and generation loss penalties, it is estimated that retrofitting an existing power station with CO₂ capture would cost 10 to 30% more than incorporating CO₂ capture into a new power station (McKinsey, 2008).

1.2.5. Further Work Required

The capture stage is the most important in determining the overall cost of CCS. Cost reductions of solvent absorption systems, new separation systems, new ways of deploying existing separations, and new plant configurations to make capture easier and less costly can deliver *incremental* cost decreases. However, novel approaches, such as re-thinking the power generation process, are needed if *substantial* reductions in the cost of capture are to be achieved.

1.3. CO₂ Transmission/Transport

Once captured and compressed, CO₂ must be transported to a long-term storage site. In this report, the words “transport” and “transmission” are used to describe movement of CO₂ from capture to storage site, in order to distinguish from the wider concept of transport (i.e., movement of goods or people by vehicles). In principle, transmission may be accomplished by pipeline, marine tankers, trains, trucks, compressed gas cylinders, as a CO₂ hydrate, or as solid dry ice. However, only pipeline and tanker transmission are commercially reasonable options for the large quantities of CO₂ associated with centralised collection hubs or point source emitters such as power stations of 500MWe capacity or greater. Trains and trucks are used in some present pilot studies (Schwarze Pumpe project, Vattenfall 2009) and may be appropriate for small volumes of CO₂ over short distances.

1.3.1. Pipelines

Pipelines have been used for several decades to transmit CO₂ obtained from natural underground or other sources to oil fields for enhanced oil recovery purposes. More than 30 million tonnes of CO₂

per year are transmitted through more than 3,000km of high-pressure CO₂ pipelines in North America. The Weyburn pipeline, which transports CO₂ from a coal gasification plant in North Dakota, USA, to an enhanced oil recovery (EOR) project in Saskatchewan, Canada, is the first demonstration of large-scale integrated CO₂ capture, transmission, and storage. Eventually, CO₂ pipeline grids, similar to those used for natural gas transmission, will be built as CCS becomes widely deployed. Figure 5 indicates the likely range of costs for the transmission of CO₂ through onshore and offshore pipelines.

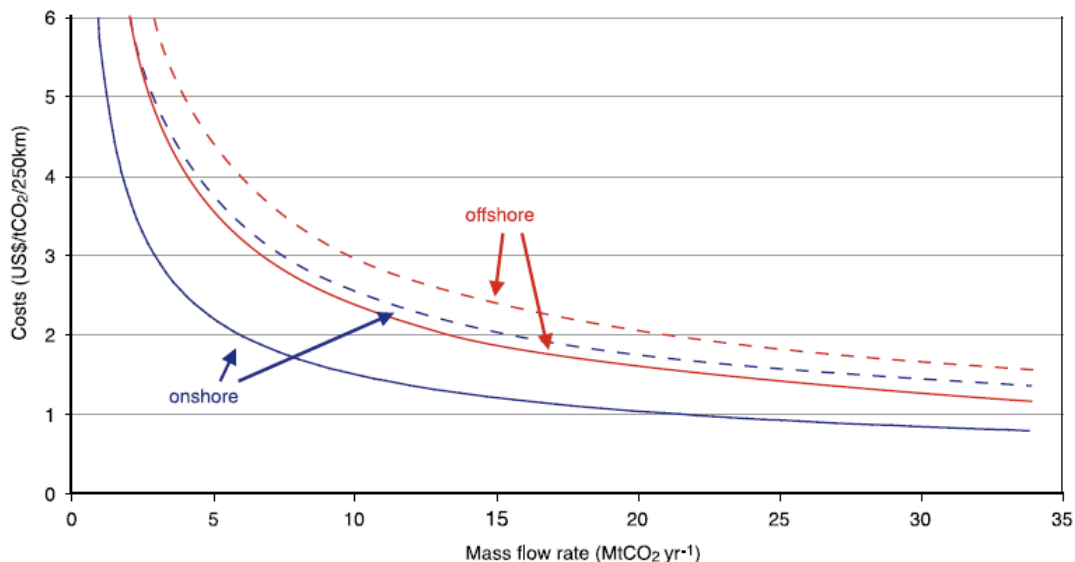

Figure 5. Range of CO₂ transport costs for onshore and offshore pipelines per 250 km. Solid lines show low range values and dotted lines high range values (Source: OECD/IEA, 2008)

1.3.2. Ship Tankers

Large scale tanker transport of CO₂ from capture sites located near appropriate port facilities may occur in the future (smaller tankers in the scale of 1,500m³ have been operating in the North Sea area for more than 10 years). The CO₂ would be transported in marine vessels such as those currently deployed for LNG/LPG transport as a pressurised cryogenic liquid (at high pressure/low temperature conditions). This would require relatively high purity CO₂. Ships offer increased flexibility in routes and they may be cheaper than pipelines, particularly for longer distance transportation. It is estimated that the transport of 6MtCO₂ per year over a distance of 500km by ship would cost about 10USD\$/tCO₂, while transporting the same 6MtCO₂ a distance of 1,250km would cost about 15USD\$/tCO₂ (OECD/IEA 2008).

1.4. Storage of CO₂

1.4.1. General Considerations

Storage of CO₂ must be safe, permanent, and available at a reasonable cost, conform to appropriate national and international laws and regulations, and enjoy public confidence. The Intergovernmental Panel on Climate Change's Special Report on Carbon Dioxide Capture and Storage (2005) provides a thorough grounding in all aspects of CCS, with a focused discussion of storage in Chapter 5 (IPCC, 2005).

The previous Road Map noted that captured CO₂ can be stored:

- in certain types of geological formations;
- through mineralisation and industrial use; and possibly; and
- by injecting it into the ocean.

Each option is reviewed below.

1.4.2. Geologic Storage

Most of the world's carbon is held in geological formations: locked in minerals, in hydrocarbons, or dissolved in water. Naturally occurring CO₂ is frequently found with petroleum accumulations, having been trapped either separately or together with hydrocarbons for millions of years.

Subject to specific geological properties, several types of geological formations can be used to store CO₂ (Figure 6). Of these, deep saline-water saturated formations, depleted oil and gas fields, and unmineable coals have the greatest potential capacity for CO₂ storage. CO₂ can be injected and stored as a supercritical fluid in deep saline formations and depleted oil and gas fields, where it migrates, like other fluids (water, oil, gas) through the interconnected pore spaces in the rock. Supercritical conditions for CO₂ occur at 31.1°C and 7.38 MPa, which occurs approximately 800m below surface level where it has properties of both a gas and a liquid and is 500–600 times more dense (up to a density of about 700kg/m³) than at surface conditions, while remaining more buoyant than formation brine. CO₂ can also be injected into unmineable coal beds where it is stored by adsorption onto the coal surface, sometimes enhancing coal bed methane production.

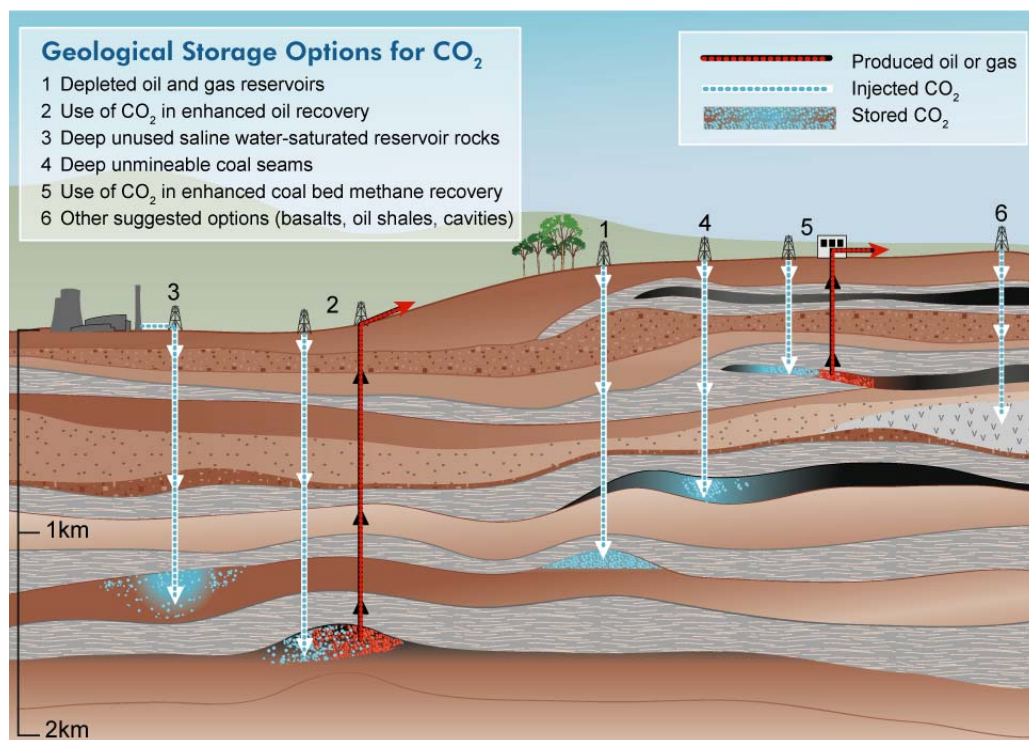

Figure 6. Geological options for CO₂ storage (courtesy of the Cooperative Research Centre for Greenhouse Gas Technologies)

1.4.2.1. Deep Saline Formations

Deep saline formations provide by far the largest potential volumes for geological storage of CO₂. These brine-filled sedimentary reservoir rocks (e.g., sandstones) are found in sedimentary basins and provinces around the world, although their quality and capacity to store CO₂ varies depending on

their geological characteristics. Based on crude estimates, the total CO₂ storage capacity of these formations is sufficient to store many decades of CO₂ production. To be suitable for CO₂ storage, saline formations need to have sufficient porosity and permeability to allow large volumes of CO₂ to be injected in a supercritical state and be overlain by an impermeable cap rock, or seal, to prevent CO₂ migration into overlying fresh water aquifers, other formations, or the atmosphere.

The chief advantages of deep saline formations for CO₂ storage are their widespread nature and potentially huge available volumes.

The Sleipner project in the Norwegian sector of the North Sea was the first demonstration of CO₂ storage in a deep saline formation designed specifically in response to climate change mitigation. Injection of approximately one million tonnes of CO₂ per year (captured from a natural gas stream) into the Utsira Formation at a depth of about 1,000m below the sea floor, began in 1996. The CO₂ is being monitored through an international project established by StatoilHydro with the IEA Greenhouse Gas R&D Programme (StatoilHydro, 2008). Following Sleipner, several other large-scale deep saline formation storage projects have also come on line, including:

- The In Salah Gas project in Algeria, where, since 2004, 1.2 million tonnes of CO₂ per year have been injected into the aquifer portion of the gas reservoir at a depth of 1,800m (StatoilHydro, 2008); and
- The Snøhvit LNG project in the Barents Sea, where, since 2008, 700,000 tonnes of CO₂ per year have been stored in a saline formation 2,500m beneath the sea floor (StatoilHydro, 2008).

Both projects have associated monitoring programs.

1.4.2.2. Depleted Oil and Gas Reservoirs

Oil and gas reservoirs are a subset of saline formations and therefore generally have similar properties, that is, a permeable rock formation (reservoir) with an impermeable cap rock (seal). The reservoir is that part of the saline formation that is generally contained within a structural closure (e.g., an anticline or dome), and was therefore able to physically trap and store a concentrated amount of oil and/or gas.

Conversion of many of the thousands of depleted oil and gas fields for CO₂ storage should be possible as the fields approach the end of economic production. There is high certainty in the integrity of the reservoirs with respect to CO₂ storage, as they have held oil and gas for millions of years. However, a major drawback of oil and gas reservoirs compared with deep saline aquifers is that they are penetrated by many wells of variable quality and integrity, which themselves may constitute leakage paths for the stored CO₂. Care must be taken to ensure that exploration and production operations have not damaged the reservoir or seal (especially in the vicinity of the wells), and that the seals of shut-in wells remain intact. Costs of storage in depleted fields should be reasonable as the sites have already been explored, their geology is reasonably well known, and some of the oil and gas production equipment and infrastructure could be used for CO₂ injection.

The major difference between depleted oil fields and depleted gas fields is that all oil fields contain unproduced oil after production has ceased, whereas nearly all of the gas in gas fields can be produced. Depleted gas fields possess significant storage capacity due to their large size and high recovery factor (>80%), as opposed to oil reservoirs whose recovery factor can be as low as 5%. EOR methods, using water, N₂, or CO₂, are often employed to extract more of the oil after primary production has waned (see section 1.4.1). CO₂ injection should therefore trigger additional production which may help offset the cost of CO₂ storage. In this sense, storage in depleted oil

reservoirs will involve an element of (EOR), while CO₂ injection into depleted gas reservoirs may not result in additional gas production.

It is important to note that the storage capacity of depleted oil and gas fields is small relative to the potential capacity of deep saline formations and to CO₂ emissions. However, they do present an early opportunity for CO₂ storage, particularly where associated with EOR. Deep saline formations around, beneath, or above depleted oil and gas fields could be used for CO₂ storage.

1.4.2.3. Unmineable Coal Beds

Coal beds below economic mining depth could be used to store CO₂. CO₂ injected into unmineable coal beds is adsorbed onto the coal and stored as long as the coal is not mined or otherwise disturbed. Methane, which occurs naturally with coal, will be displaced when CO₂ is injected and can result in enhanced coal bed methane (ECBM) production (discussed further in section 3.2.4).

CO₂ storage in coal is limited to a relatively narrow depth range, between 600m and 1,000m, and less than 1,200m. Shallow beds less than 600m deep have economic viability and beds at depths greater than 1,000m have decreased permeability for viable injection. A significant problem with injection of CO₂ into coal beds is the variable, and sometimes very low, permeability of the coal, which may require many wells for CO₂ injection. Coal may also swell with adsorption of CO₂ which will further reduce existing permeability. Low permeability can, in some cases, be overcome by fracturing the coal formation; however, there is the risk of unintended fracturing of the cap rock layer, increasing the potential for CO₂ migration out of the intended storage zone. Another drawback of CO₂ storage in coals is that at shallow depths they may be within the zone of protected groundwater, which is defined as water with salinity below 4,000 to 10,000 mg/L, depending on jurisdiction. In such cases, the depth interval of coals potentially suitable for CO₂ storage will be further reduced.

Storage in unmineable coal beds has and is being investigated in several pilot projects worldwide (National Energy Technology Laboratory, 2008).

1.4.2.4. Other Geological Storage Options

Other geological CO₂ storage options include injection into basalt, oil shale, salt caverns and cavities, geothermal reservoirs, and lignite seams, as well as methano-genesis in coal seams or saline formations. These are in early stages of development, and appear to have limited capacity except, possibly, as niche opportunities for emissions sources located far from the more traditional, higher capacity storage options.

1.4.3. Mineralisation

Nature's way of geologically storing CO₂ is the very slow reaction between CO₂ and naturally occurring minerals, such as magnesium silicate, to form the corresponding mineral carbonate.

Dissolution of CO₂ in water forms carbonic acid — a weak acid:

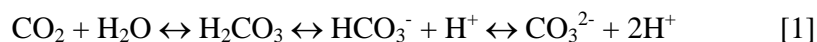

The carbonic acid can then react with the calcium, magnesium, and iron in carbonate and silicate minerals such as clays, micas, chlorites, and feldspars to form carbonate minerals such as calcite (IPCC, 2005):



Of all forms of carbon, carbonates possess the lowest energy, and are therefore the most stable. CO₂ stored as a mineral carbonate would be permanently removed from the atmosphere. Research is underway to increase the carbonation rate, however, the mass of mineral that would have to be

quarried would be many times the mass of CO₂ captured. At present, this option would be considerably more expensive than others.

A novel example of mineralisation undergoing pilot-scale trials is the chemical conversion of refining wastes, such as bauxite residue (red mud), by combining with CO₂. While ideally suited to lower CO₂ volumes, the process addresses CO₂ storage needs while reducing the environmental issues associated with the caustic form of the residue if stored as a carbonate when reacted with CO₂.

1.4.4. Deep Ocean Storage

Two types of CO₂ injection into the ocean have been considered in the past. In the first, the CO₂ would be injected at depth, to dissolve in the seawater. In the second, concentrated CO₂ in liquid or solid hydrate form would be isolated either on or under the sea bed. The deep oceans have, in principle, capacity for retaining CO₂ for hundreds of years.

Increased acidity near the point of CO₂ injection is a primary environmental concern. Due to these effects, the International Maritime Organisation stated that CO₂ can only be dumped into the ocean if disposed in a sub-seabed geological formation (International Maritime Organisation, 2007). It is noted that such issues as dumping into the water-column and on the seabed may be dealt with in the future but, based on current understanding, this report does not consider deep ocean storage of CO₂ any further.

1.4.5. Security of Storage

Natural deep subsurface accumulations of CO₂ occur in many sedimentary basins around the world and, like oil and gas, can be a valuable, extractable resource. Pure CO₂ is a commercial commodity with widespread application in the food and beverage industry. These accumulations provide evidence that CO₂ can be and have been stored over millions of years—they are natural analogues for understanding the geological storage of captured greenhouse gasses.

1.4.5.1. Natural Analogues of CO₂ Storage

CO₂ accumulations occur naturally in geological formations, often in association with hydrocarbons. Core sampling of these natural accumulations provides information on the geochemical reactions that occur between stored CO₂ and the rock. Evidence of low rates of leakage has been found at some natural sites, which provides a laboratory to study environmental and safety implications, as well as measurement, monitoring and verification (MMV) techniques. The fact that CO₂ has been securely stored for millions of years in places like commercial gas fields (Miyazaki et al., 1990) is important in understanding the fate of CO₂ stored underground.

1.4.5.2. Commercial Analogues of CO₂ Storage

Transportation and certain aspects of CO₂ storage are similar in many respects to natural gas transportation and storage. Natural gas is widely transported around the world via pipelines and ships, and is stored in several hundred sites around the world, some for more than 60 years, in geological formations to ensure constant supply. While small in comparison to the volumes of CO₂ to be stored as a result of CCS, significant quantities of CO₂ are routinely transported by pipeline in association with enhanced oil recovery projects (IPCC, 2005). Operating procedures and safety standards have been developed, and there is increasing experience with underground injection of CO₂.

With gas re-injection, either for storage or EOR, reservoir over-pressurisation could activate or cause fractures and lead to leakage: application of engineering techniques, in response to rock properties, and understanding fluid systems, should prevent this from occurring. The greatest concern about

CO₂ storage in oil and gas fields is the integrity of the many wells drilled during the exploration and production phases of the operation. Cement degradation, casing corrosion, or damage to the formation near the well could result in leakage. But as in standard oilfield practise, there are mitigation strategies that can be put in place to ensure well integrity.

1.4.5.3. Understanding Leakage

Naturally occurring CO₂ leakage does occur in tectonic active areas and near volcanoes. These sites can show us the effect of leakage on the geosphere and biosphere. Sites selected for underground storage for CO₂ will:

- Undergo rigorous analysis to ensure they are capable of permanent storage; and
- Have a rigorous detection, monitoring, and verification of storage program in place to track the migration of CO₂ in the storage formation.

In the unlikely event that underground leakage pathways are established, the CO₂ could migrate upward and could mix with water in overlaying aquifers or even reach the surface. Trapping mechanisms such as mineralisation, dissolution, and residual trapping, occurring along the migration pathway will result in only a small fraction of the injected CO₂ having the potential to reach the surface and, should a leak be detected, remediation actions would be implemented.

1.4.5.4. Risk Assessment

Extensive experience exists in the oil and gas industry for gas transport and injection, including CO₂. As such, those risks are well understood. Modelling studies assist in assessing for assessing the long-term behaviour and migration of stored CO₂ although field data to validate these models is still lacking. Comprehensive system approaches for risk assessment are being developed and applied as part of all capture, transport, and storage programs. Monitoring is an essential factor in mitigating risk.

Environmental impact assessments incorporating risk assessments and methods for managing risks are required where new operations or significant changes in existing operations are planned. A solid technological foundation through technology developments, demonstrations, and risk assessment methodologies will be needed in order to garner broad public acceptance as well as contributing to the creation of a sound regulatory framework for geological CO₂ storage.

1.5. Uses for CO₂

Commercially produced CO₂ is an expensive product for enhancing oil, gas and coal bed methane production; biofixation; and for making industrial and food products. Cost offsets can be achieved by redirecting pure-stream CO₂ from capture projects. The total quantity of CO₂ that could be used will be much less than the total quantity that could be captured, but there is potential for research into new industrial uses of CO₂ or for CO₂ as a feedstock into other processes as discussed in 1.4.3.

1.5.1. Enhanced Oil and Gas Recovery (EOR and EGR)

Primary, conventional oil production techniques may only recover a small fraction of oil in reservoirs, typically 5–15% (Tzimas et al., 2005), although initial recovery from some reservoirs may exceed 50%. For the majority, secondary recovery techniques such as water flooding can increase recovery to 30–50% (Tzimas et al., 2005). Tertiary recovery techniques such as CO₂ injection, which is already used in several parts of the world, mostly in the Permian basin in the United States of America, pushes recovery even further. At present, most of the CO₂ used for enhanced oil recovery is obtained from naturally occurring CO₂ fields or recovered from natural gas production.

Because of the expense, CO₂ is recycled as much as possible throughout the EOR process but the CO₂ left in the reservoir at the end of recovery is for all intents and purposes permanently stored.

At the end of 2007, there were 95 active CO₂-EOR projects worldwide, the vast majority in the USA (Moritis, 2008). In 2005, 5.7 million tonnes of CO₂ was captured from six point sources for EOR use. The largest of these, the Dakota Gasification Plant in North Dakota, USA, provides 1.75 million tonnes of CO₂ annually to the Weyburn EOR project in Saskatchewan, Canada, some 330km away. This was the first major project designed to demonstrate the long-term effectiveness of CO₂ capture coupled with EOR. Currently, about 3.2 million tonnes of CO₂ are injected for EOR at the EnCana and Apache fields at Weyburn each year, with approximately 35 million tonnes of CO₂ expected to be stored in total (Petroleum Technology Research Centre, 2008).

Enhanced gas recovery is different because it is possible to produce almost all of the original gas in place through primary production techniques. However, injection of CO₂ into a producing gas reservoir will help maintain reservoir pressure and increase the rate of gas production. Because of rapid CO₂ expansion in the reservoir, breakthrough will occur rather rapidly and CO₂ will be produced along with the gas, necessitating separation of the CO₂ from the natural gas, in a way mimicking the current operations at Sleipner and In Salah, and also at all acid gas disposal operations in North America. Initially, when CO₂ concentrations in the produced gas are low, it may be possible to separate and re-inject the CO₂, however, the CO₂ concentration will increase with time and eventually separation and re-injection will not be feasible. At this point gas production will end and CO₂ will be stored in the depleted reservoir. The costs associated with the need of separating the CO₂ from the produced gas will most likely not justify enhanced gas recovery operations.

CO₂ can be injected into methane-saturated coal beds and will preferentially displace adsorbed methane, thereby increasing methane production. Coal can adsorb about twice as much CO₂ by volume as methane, and the adsorbed CO₂ is permanently stored. Several enhanced coal bed methane recovery pilot or demonstration projects have been conducted worldwide, including in the USA, China, and Europe.

1.5.2. Biofixation

Biofixation is a technique for production of biomass using CO₂ and solar energy, typically employing microalgae or cyano-bacteria. Horticulture (in glass houses) often uses CO₂ to enhance the growth rates of plants by artificially raising CO₂ concentrations.

Depending on the use of the material grown in this way, there may be some climate change benefits. For example, microalgae can be grown in large ponds to produce biomass, which can then be converted into gas or liquid fuels, or high value products such as food, fertilisers, or plastics. However, the demand for high value products is currently insufficient to justify large-scale capture of CO₂; the carbon is only fixed for a short time and there are challenges associated with the resource and space requirements to allow large-scale CO₂ fixation.

1.5.3. Industrial Products

CO₂ captured from ammonia (NH₃) reformer flue gas is now used as a raw material in the fertiliser industry for the manufacture of urea, and purified CO₂ is used in the food industry. Possible new uses include the catalytic reduction of light alkanes to aromatics using CO₂, formation of alkylene polycarbonates used in the electronics industry, and the production of dimethylcarbonate as a gasoline additive.

Because CO₂ is thermodynamically stable, significant energy is needed in its conversion for use as a chemical raw material. The additional energy requirement and cost may preclude its use as a

chemical raw material in all but a few niche markets. CO₂ used for producing industrial products will normally release within a few months or years. To successfully mitigate the risk of climate change, CO₂ needs to be stored for thousands of years (IPCC, 2005).

1.6. The Potential for CO₂ Storage

Economically, once the more profitable offsets for CO₂ injection have been exploited, the storage of CO₂ will need other cost drivers to ensure its financial viability such as a cost on carbon. Storage of CO₂ in oil and gas reservoirs will have the advantage that the geology of reservoirs is well known and existing infrastructure may be adapted for CO₂ injection. The same does not apply to unmineable coal seams or storage in deep saline formations which collectively may be exposed to higher overall storage cost structures because of lack of offsets.

Figure 7 indicates the theoretical global storage capacity for deep saline formations, depleted oil and gas reservoirs, and unmineable coal seams. Note that these capacity estimates are broad indications only, with high ranges of uncertainty, and include non-economical options.

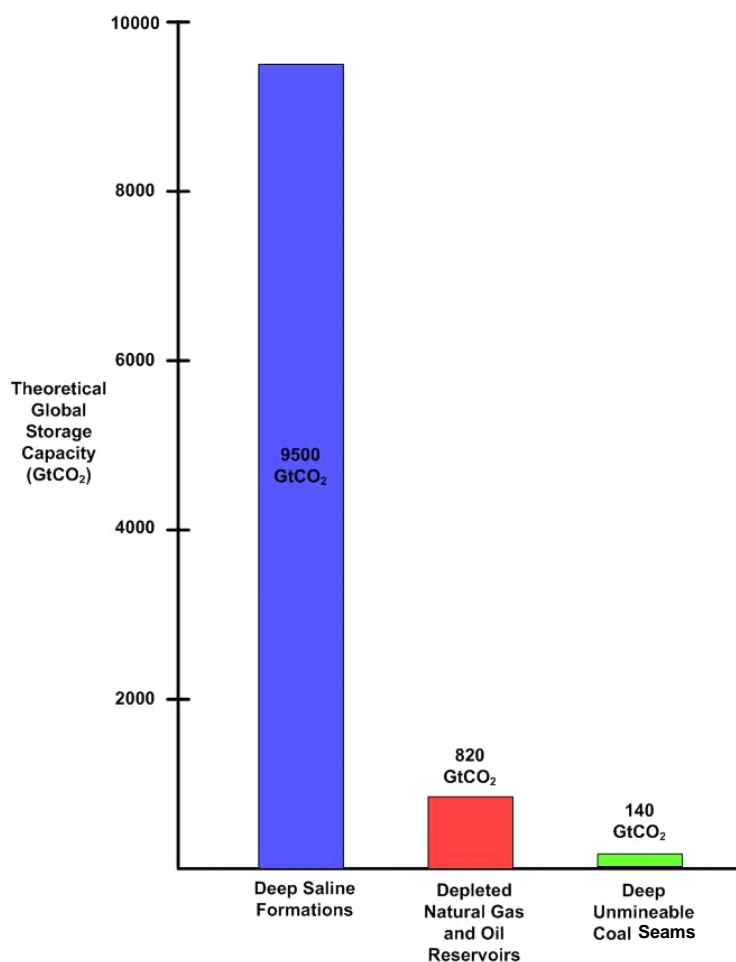

Source: The Global Energy Technology Strategy Program: Carbon Dioxide Capture and Geological Storage: A Core Element of a Global Technology Strategy to Address Climate Change, 2006

Figure 7. The theoretical global storage capacity of CO₂

Many factors influence the costs of storage and these are very site-specific (e.g., the number of injection wells required, onshore versus offshore, and so on). However, the storage component of CCS is generally held to be the cheapest part of the process, in which the costs of capture dominate. Figure 8 (table) shows estimates of CO₂ storage costs.

Option	Representative Cost Range (US\$/tonne CO ₂ stored)	Representative Cost Range (US\$/tonne C stored)
Geological - Storage ^a	0.5-8.0	2-29
Geological - Monitoring	0.1-0.3	0.4-1.1
Ocean ^b		
Pipeline	6-31	22-114
Ship (Platform or Moving Ship Injection)	12-16	44-59
Mineral Carbonation ^c	50-100	180-370

^a Does not include monitoring costs.

^b Includes offshore transportation costs; range represents 100-500 km distance offshore and 3000 m depth.

^c Unlike geological and ocean storage, mineral carbonation requires significant energy inputs equivalent to approximately 40% of the power plant output.

Figure 8. Estimates of CO₂ storage costs (Source: IPCC, 2005)

Power Station Performance and Costs: With and Without CO₂ Capture

The Intergovernmental Panel on Climate Change (IPCC), the International Energy Agency (IEA), McKinsey & Company, and other organisations have evaluated the performance and costs of power generation options with and without CO₂ capture. These sources have been utilised in this Technology Roadmap but it should be noted that across the CCS industry, a wide range of models, variables, units, and values are used.

Electricity generation technologies considered in this section include supercritical pulverised coal fuel (PC), integrated gasification combined cycle (IGCC), and natural gas combined cycle (NGCC) plants. These power station types have been included in this analysis because they hold promise for CCS and there is a greater body of reliable information relating to these technology types. Other configurations may be considered in future revisions of this document.

Power Station Performance

Figure 9 shows the conceptual costs associated with the capture of carbon dioxide from power stations. The cost of CCS is defined as the additional full cost (i.e., including initial investments and ongoing operational expenditures) of a CCS power station compared to the costs of a state-of-the-art non-CCS plant, with the same net electricity output and fuel usage.

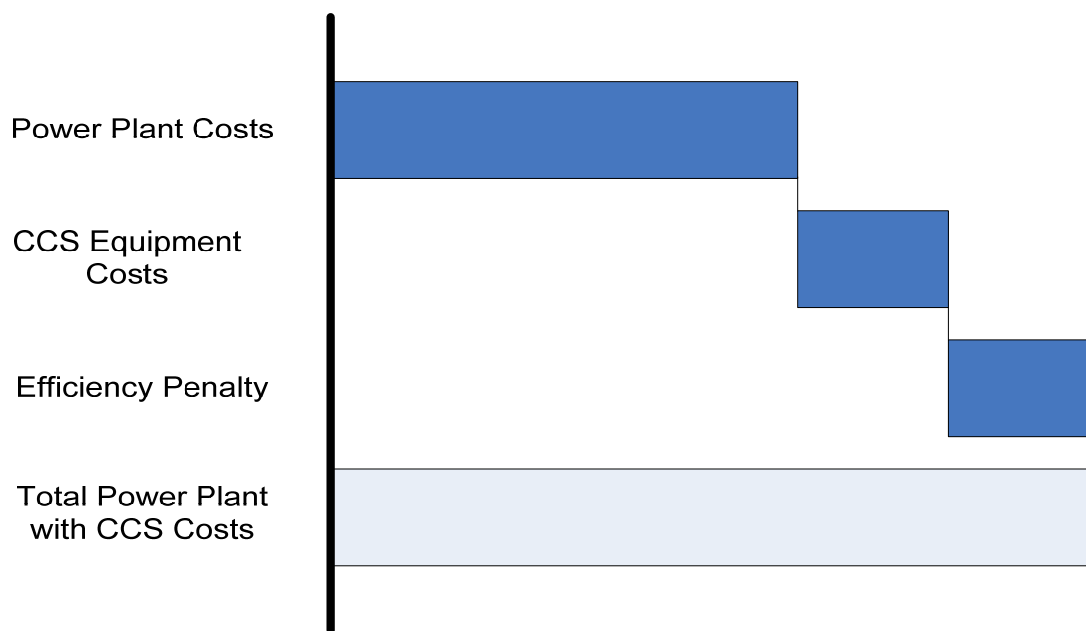

Source: McKinsey & Co., *Carbon Capture and Storage: Assessing the Economics*, 2008

Figure 9. The conceptual costs associated with CO₂ capture for power stations

Current studies indicate that a decrease of power station efficiency by 14 percentage points can occur with the addition of CO₂ capture (OECD/IEA, 2008). Most of this is attributable to the additional energy requirements for the capture process. The actual efficiency shortfalls vary significantly on a case-by-case basis with the key determinants being technology type and fuel type. These ranges are shown in Figure 10.

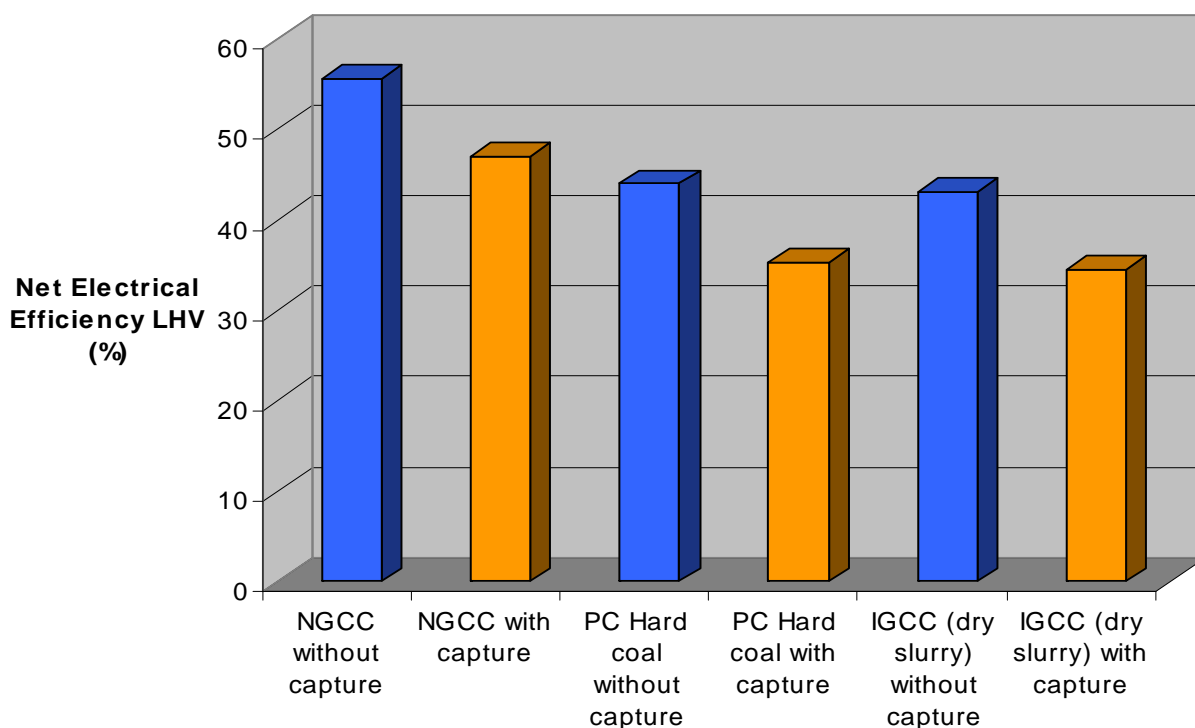

Figure 10. Power station generation efficiencies with and without the capture of CO₂ (Source: IEA Greenhouse Gas R&D Programme, 2007)

Power Generation Costs

On average, CO₂ capture and compression increases the capital cost of an NGCC plant by 76%, a PC plant by 63%, and an IGCC plant by 37% (Figure 11). The order of capital costs is the same with or without CO₂ capture — the NGCC plant is least expensive and the IGCC plant is most expensive.

Performance and cost measures	New NGCC plant			New PC plant			New IGCC plant		
	Range		Rep. value	Range		Rep. value	Range		Rep. value
	Low	High		Low	High		Low	High	
Emission rate without capture (kgCO ₂ /kWh)	0.344	0.379	0.367	0.736	0.811	0.762	0.682	0.846	0.773
Emission rate with capture (kgCO ₂ /kWh)	0.040	0.066	0.052	0.092	0.145	0.112	0.065	0.152	0.108
Percentage CO ₂ reduction per kWh (%)	83	88	86	81	88	85	81	91	86
Plant efficiency with capture, LHV basis (%)	47	50	48	30	35	33	31	40	35
Capture energy requirement (% increase input/kWh)	11	22	16	24	40	31	14	25	19
Total capital requirement without capture (US\$/kW)	515	724	568	1161	1486	1286	1169	1565	1326
Total capital requirement with capture (US\$/kW)	909	1261	998	1894	2578	2096	1414	2270	1825
Percent increase in capital cost with capture (%)	64	100	76	44	74	63	19	66	37
COE without capture (US\$/kWh)	0.031	0.050	0.037	0.043	0.052	0.046	0.041	0.061	0.047
COE with capture only (US\$/kWh)	0.043	0.072	0.054	0.062	0.086	0.073	0.054	0.079	0.062
Increase in COE with capture (US\$/kWh)	0.012	0.024	0.017	0.018	0.034	0.027	0.009	0.022	0.016
Percent increase in COE with capture (%)	37	69	46	42	66	57	20	55	33
Cost of net CO ₂ captured (US\$/tCO ₂)	37	74	53	29	51	41	13	37	23
Capture cost confidence level (see Table 3.6)	moderate			moderate			moderate		

Figure 11. A summary of the CO₂ capture costs for new power stations based on current technology. Costs presented do not include the costs (or credits) for CO₂ transport and storage (Source: IPCC, Special Report on Carbon Dioxide Capture and Storage, 2005)

An NGCC plant without CO₂ capture has the lowest cost of electricity at 3.7¢/kWh. Adding CO₂ capture increases the cost by about 1.7¢/kWh. The addition of CO₂ capture to a coal plant increases the cost of electricity by 1.6 – 2.7¢/kWh depending on the cost of fuel and type of plant. Further costs would be added to the supply of electricity when including the costs associated with the transport and storage of CO₂.

Figure 12 brings together information on power station capital costs, CCS costs, and CCS efficiency penalty costs to provide estimates of the total cost of power station types with CCS. The graph is based on the data contained in Figure 9 and demonstrates what the total costs of CCS would be for a 500MW power station operating with 85% capacity factor.

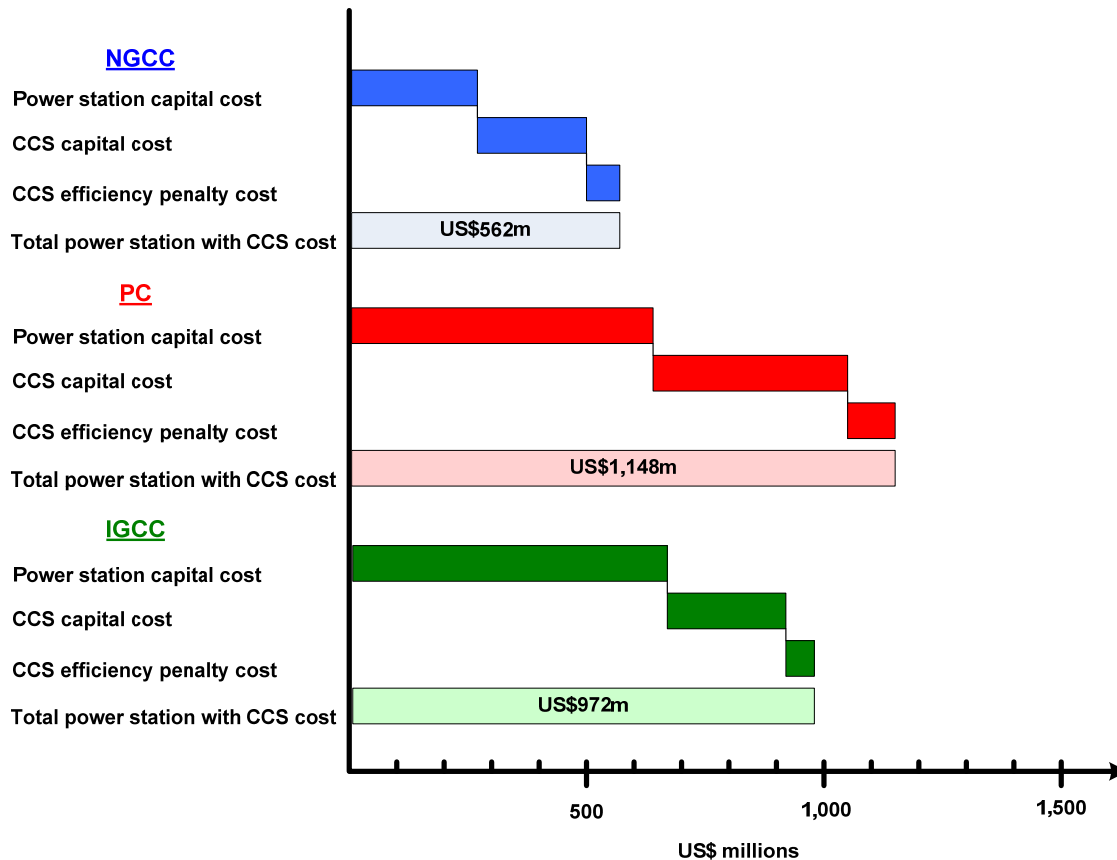

Figure 12. A comparison of the total cost of CCS for different power station types with a 500MW unit operating with 85% capacity factor (Source: IPCC, Special Report on Carbon Dioxide Capture and Storage, 2005)

MODULE 2: ONGOING ACTIVITIES IN CO₂ CAPTURE AND STORAGE

2.1. Introduction

This module summarises ongoing activities on the capture and storage of CO₂. Figures 13 and 14 show the increase in global activities in CCS over the past four years based on currently available information from the IEA Greenhouse Gas R&D Programme and Cooperative Research Centre for Greenhouse Gas Technologies project databases. While there are other databases on CCS projects, there is broad differentiation in the project information provided and the terms and criteria used to define a project. Due to this information gap, Figures 13 and 14 may not be complete. This gap also highlights the need for collaboration on an internationally agreed upon CCS project database.

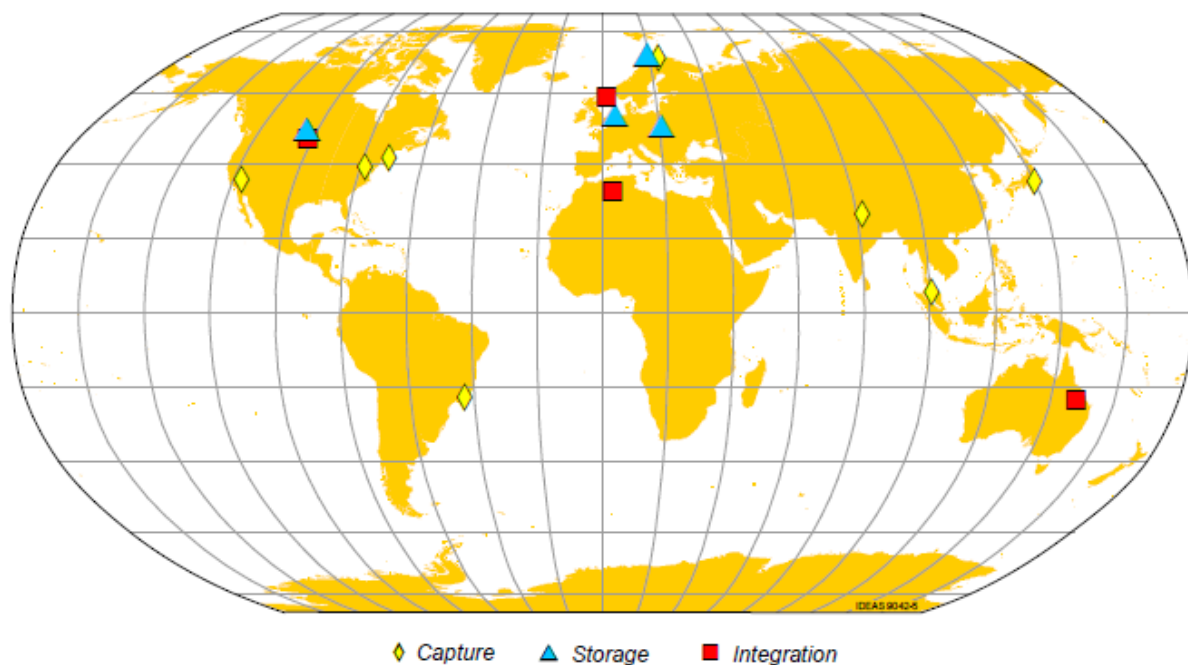

Figure 13. Commercial and demonstration CCS projects announced or commenced in or before 2004



Figure 14. Commercial and demonstration CCS projects either announced or commenced before 2009

2.2. CSLF Activities and Achievements

The CSLF 2004 Technology Roadmap identified six key activities which were carried out in the period 2004 to 2008 to address cost reductions, reservoirs, and monitoring and verification (Figure 15).

Topic/Timescale	2004–2008	2009–2013	2014 +
Lower Costs	<ul style="list-style-type: none"> Identify most promising pathways Set ultimate cost goals 	<ul style="list-style-type: none"> Initiate pilot or demonstration projects for promising pathways 	<ul style="list-style-type: none"> Achieve cost goals of reduced CCS setup and operations combined with increases in process/electricity generation efficiencies
Secure Reservoirs	<ul style="list-style-type: none"> Initiate field experiments Identify most promising reservoir types 	<ul style="list-style-type: none"> Develop reservoir selection criteria Estimate worldwide reservoir “reserves” 	<ul style="list-style-type: none"> Large scale implementation
Monitoring and Verification Technologies	<ul style="list-style-type: none"> Identify needs Assess potential options 	<ul style="list-style-type: none"> Field tests 	<ul style="list-style-type: none"> Commercially available technologies

Figure 15. 2004 CSLF Technology Roadmap

Recently completed and ongoing CSLF activities include:

- The development of CO₂ storage capacity estimations (Phase I, II, & III);
- Identification of technology gaps in monitoring and verification of geologic storage;
- Identification of technology gaps in CO₂ capture and transport; and
- Ongoing work to examine risk assessment standards and procedures.

More detailed descriptions of CSLF member program activities can be found on the CSLF web site www.cslforum.org.

2.3. CCS Project Activities

This section presents a number of projects that correlates with Figures 12 and 13. However it is not an exhaustive list as additional projects continue to be announced as the technology is taken forward.

Across the world there are four operational commercial-scale integrated CCS projects. These projects are motivated and/or linked to oil and gas production and include:

1. The **Sleipner project in Norway** (StatoilHydro + partners in Sleipner license), where since 1996, more than 1 million tonnes per year (Mt/a) of CO₂ has been captured during natural gas extraction and re-injected 1,000m below the sea floor into the Utsira saline formation.
<http://www.statoilhydro.com/en/technologyinnovation/protectingtheenvironment/carboncaptureandstorage/pages/captureandstorageofco2.aspx>
2. The **In Salah project in Algeria** (BP with Statoil and Sonatrach as partners) where since 2004, about 1 Mt/a of CO₂ has been captured during natural gas extraction and injected into the Krechba geologic formation at a depth of 1,800m.
<http://www.statoilhydro.com/en/technologyinnovation/protectingtheenvironment/carboncaptureandstorage/pages/captureandstorageofco2.aspx>
3. **Snohvit in Norway**. This liquefied natural gas (LNG) plant (Petro, StatoilHydro, TotalFinaElf, Gaz de France, Amerada Hess, RWE-DEA, Svenska Petroleum) captures 0.7 Mt/a of CO₂ and injects it into the Tubåen sandstone formation 2,600m under the seabed for storage.
<http://www.statoilhydro.com/en/technologyinnovation/protectingtheenvironment/carboncaptureandstorage/pages/captureandstorageofco2.aspx>
4. The **Weyburn-Midale project in Canada** (EnCana – Apache) captures about 2.8 Mt/a of CO₂ from a coal gasification plant located in North Dakota, USA, transports this by pipeline 320 km across the Canadian border and injects it into depleting oil fields where it is used for EOR.
<http://www.netl.doe.gov/publications/factsheets/project/Proj282.pdf>

Three pilot plant projects which are more focused on CO₂ capture and storage in the energy sector are:

1. The **Ketzin CO₂ storage pilot near Berlin, Germany** (GeoForschungs Zentrum Potsdam) started injection in June 2008. Two observation wells and a series of different technologies allow on-land testing of monitoring techniques without disturbing industrial activities and at lower costs than offshore or in a desert. Present plans will allow 20,000 t CO₂/year to be injected.
<http://www.co2sink.org/>
2. The **Schwarze Pumpe pilot plant in Germany** (Vattenfall) commenced operations in 2008. Based on an oxy-combustion concept, CO₂ is captured from the flue gas after deSO_x and deNO_x processes. It is planned to store CO₂ in a depleted gas field (Altmark) operated by Gaz de France.
http://www.vattenfall.com/www/vf_com/vf_com/Gemeinsame_Inhalte/DOCUMENT/360168vat/5965811xou/902656oper/1557089ccs/P02.pdf
3. The **Lacq pilot plant in France** (Total) which is planned to start in 2009. This is a 30 MW gas boiler project that will use oxy-combustion capture technology; CO₂ will be transported in an existing 30km pipe and stored in a very deep (4,500m) depleted gas field.
<http://www.total.com/static/en/medias/topic2627/lacq-pilot-information-dossier.pdf>

In addition, there are also 24 other major project announcements from around the world. These include:

1. The **ZeroGen project in Australia**, which will use IGCC with pre-combustion capture technology at a 400MW coal-fired power station and store the CO₂ in deep saline formations in the Northern Denison Trough approximately 220 km from the plant. Demonstration is expected by 2012, with full-scale operation by 2017. <http://www.zerogen.com.au/project/overview.aspx>
2. The **Fort Nelson project in British Columbia, Canada**, which will use CCS at a gas plant after amine separation of the CO₂ from the produced natural gas. Storage of CO₂ will be in a nearby saline formation. CO₂ injection is expected to begin in 2011 and ramp up to 1.2 to 2 Mt CO₂/year. http://www.netl.doe.gov/publications/proceedings/08/rcsp/factsheets/19-PCOR_Fort%20Nelson%20Demonstration_PhIII.pdf
3. The **Vattenfall project at Aalborg, Denmark**. A 380 MW highly efficient coal-fired combined heat and power plant. Biomass co-firing is being introduced for true zero and possibly negative emission with CCS. The project uses post-combustion amine-based CO₂ capture, and a 28km pipeline to transport storage in a deep onshore saline aquifer. 2D seismic mapping completed, 3D seismic mapping and first 2-3 wells to be done in 2009. Storage of some 1.8 Mt CO₂ per year. Injection of CO₂ is expected to start in 2013. http://www.vattenfall.com/www/co2_en/co2_en/879177tbd/879231demon/879304demon/index.jsp
4. Shell's **Quest project in Alberta, Canada**, which will store about 1 Mt CO₂/year captured at a hydrogen plant at its oil sands upgrader in central Alberta; injection is expected to begin in 2011. http://www-static.shell.com/static/ca-en/downloads/about_shell/what_we_do/oil_sands/quest-public-disclosure-v9.pdf
5. The **Redwater HARP project in Alberta, Canada**, which will store similar amounts of CO₂ captured at refineries, oil sands upgraders and chemical plants northeast of Edmonton, Alberta. Injection is expected to start in 2011 and ramp up to 1 Mt CO₂/year by 2015. <http://www.arc.ab.ca/documents/Reef%20may%20hold%20key%20to%20large-scale%20carbon%20storage.pdf>
6. The **WASP project in Alberta, Canada**, (also known as the Pioneer project) will capture CO₂ from one of the three TransAlta's coal-fired power plants in the area, using a chilled-ammonia process developed by Alstom. Injection is expected to start in 2011 or 2012. <http://alberta.ca/home/NewsFrame.cfm?ReleaseID=/acn/200810/24549060A11EE-A487-6EAB-0BA6A4955D18D734.html>
7. RWE's **Zero-CO₂ plant in Germany**, which will use IGCC with pre-combustion capture technology at a 450 MW coal-fired power station and store the CO₂ in a saline formation. Power station operation is targeted for 2015. <https://www.rwe.com/web/cms/en/2688/rwe/innovations/power-generation/clean-coal/igcc-ccs-power-plant/>
8. The **Husnes project in Norway**, a 400 MW coal-fired power station with post-combustion CO₂ capture and storage via EOR offshore in the North Sea. Project start-up is expected in 2010. http://sequestration.mit.edu/tools/projects/sargas_husnes.html
9. The **Karsto project in Norway**, a 420 MW natural gas plant which will use post-combustion capture technology and inject CO₂ offshore into a saline formation and/or for EOR. http://sequestration.mit.edu/tools/projects/naturkraft_karsto.html

10. The **Mongstad plant in Norway**, a 350 MW natural gas combined heat and power facility which will use post-combustion capture and store the CO₂ offshore in a geological formation. The plant is expected to start up in 2010, with full-scale operation in 2014.
http://www.vattenfall.com/www/vf_com/vf_com/368181envir/368469whatx/1501206focus/368501clima/883875examp/883907devel/index.jsp?WT.ac=search_success
11. The **Masdar project in the United Arab Emirates**, a 420 MW gas-fired power station with pre-combustion capture and storage of the CO₂ via EOR. Operation is expected by 2012.
<http://www.bp.com/genericarticle.do?categoryId=9024973&contentId=7046909>
12. The **Ferrybridge project in the UK**, a 500 MW coal-fired power station retrofit with a supercritical boiler and turbine, and post-combustion capture. The CO₂ will be stored in a saline formation. Project operation is expected by 2011.
http://sequestration.mit.edu/tools/projects/sse_ferrybridge.html
13. The **Hatfield project in the UK**, which will capture CO₂ from a 900 MW coal-fired power station for EOR in North Sea oilfields. Project operation is expected to begin after 2011.
<http://www.powerfuel.plc.uk/id10.html>
14. The **Antelope Valley project in the USA**, a 120 MW slipstream at a 450 MW coal-fired electricity plant. The project will use post-combustion capture technology with ammonia. The CO₂ will be transported through an existing 330 km CO₂ pipeline and injected for EOR. Commercial operation is expected in 2012.
http://sequestration.mit.edu/tools/projects/antelope_valley.html
15. The **Carson project in the USA**, a 390 MW project using IGCC at a petroleum coke plant to produce hydrogen. The CO₂ will be stored via EOR. The plant is expected to begin operation in 2014. http://sequestration.mit.edu/tools/projects/bp_carson.html
16. The **Northeastern project in the USA**, which will capture CO₂ from a 200 MW coal-fired power station fitted onto a 450 MW power station using post-combustion capture with chilled ammonia. The CO₂ will be stored via EOR. Operation is targeted for 2011.
http://www.co2crc.com.au/demo/p_northeast.html
17. The **Tenaska project in the USA**, a 600 MW coal-fired plant using supercritical pulverised coal technology and CO₂ storage via EOR. Operation is anticipated in 2014.
<http://www.tenaskatrailblazer.com/>
18. The **WA Parish Plant in the USA**, a 125 MW coal-fired power station, using post-combustion ammonia-based electrocatalytic oxidation technology for CO₂ capture. The CO₂ will be stored via EOR. The project is expected to be operational by 2012.
http://sequestration.mit.edu/tools/projects/wa_parish.html

19. The **Wallula project in the USA**, using pre-combustion capture technology at a 600 MW IGCC coal-fired power station. CO₂ storage will be in basalt at a depth of 2 km. Site construction is due to begin in 2009, with operation by 2013.
http://www.wallulaenergy.com/docs/ep_062007.pdf
20. The **Williston Basin project in the USA**, which will retrofit a 450 MW lignite-fired power station with post-combustion capture technology. The CO₂ is expected to be used for EOR. The project is expected to start in 2010. http://www.co2crc.com.au/demo/p_williston.html
21. The **Archer Daniels Midland Phase III Injection Project in the USA**, where an existing ethanol production facility will capture otherwise emitted CO₂ and store it on site in a saline formation. The project plans to begin injecting in early 2010.
http://www.netl.doe.gov/publications/press/2009/09008CO2_Injection_Well_Drilling_Begins.html
22. The **Shell project in the Netherlands**, which will capture greater than 0.2 Mt /year of CO₂ from the hydrogen production unit at the Shell refinery near Rotterdam (Pernis); storage will take place in a nearby depleted gas field.
23. The **DSM/GTI project in the Netherlands**, which will capture greater than 0.2 Mt /year of CO₂ from DSM's ammonia production unit at the Chemelot site near Sittard-Geleen; storage will take place in chalk sandstone layers (including coal layers) below the Chemelot site. <http://www.gti-group.com/en/news/gti-wins-co2-storage-at-dsm>
24. The **Buggenum IGCC project in the Netherlands**, where 1-2% of the produced syngas (representing about 2.5 MWe) will be captured in a side loop. <http://www.clean-energy.us/success/buggenum.htm>
25. The **SEQ oxyfuel project in the Netherlands**, where a 50 MWe gas-fired oxyfuel plant will be built and the captured CO₂ will be stored offshore in a depleted gas field.

2.4. Demonstration and Research Activities

As well as specific projects, there are a number of research and demonstration efforts worldwide relevant to CO₂ capture and storage with which the CSLF will endeavour to coordinate activities. These include:

1. The **IEA Greenhouse Gas R&D Programme**, which is a major international research collaboration that assesses technologies capable of achieving deep reductions in greenhouse gas emissions.
2. The **Intergovernmental Panel on Climate Change (IPCC)**, which provides an objective source of information about climate change initiatives through assessing on a comprehensive, objective, open, and transparent basis the latest scientific, technical, and socio-economic literature produced worldwide.
3. The **Global Carbon Capture and Storage Institute (GCCSI)**, which is being established to accelerate the deployment of CCS technology by supporting / initiating 20 fully integrated industrial-scale demonstration projects by 2020.
4. The **EU Zero Emissions Platform (ZEP)**, which aims to achieve 12 commercial-scale demonstration projects by 2020 and identify the conditions necessary for deployment in Europe and worldwide.

5. The **Near-Zero Emissions Coal (NZEC)** effort between the UK/EU and China, which aims to construct and operate a 450MW IGCC power station with pre-combustion capture and storage in a geological formation or through EOR by 2015.
6. The **UK CCS Competition**, which aims to award up to 100% funding to a full-scale CCS plant using post-combustion capture and offshore CO₂ storage. The intention is for the facility to be operational by 2014.
7. The **US CCS Effort**, which includes seven Regional Partnerships and aims to develop nine large-scale demonstration projects.
8. The **Technology Center Mongstad (TCM)** will be the first step towards full-scale CCS from the CHP plant and the catalytic cracker at the refinery. TCM sanction will be done in May 2009 after final approval in the Norwegian Parliament. StatoilHydro together with Shell, DONG Energy, and some new partners will own the TCM company together with the Norwegian state, represented by Gassnova. Around 100,000 tons of CO₂ annually will be captured from an amine unit and a chilled ammonia unit, with possibility to include other technologies later on.
9. The **Rotterdam Climate Initiative (RCI)** project in the Netherlands, aiming at the development of CCS projects in the Rijnmond region; capture will be at power stations as well as chemical and petrochemical plants, whereas storage will take place offshore through a newly constructed infrastructure.
10. The **Northern Netherlands CCS Coalition in the Netherlands**, stimulating CCS projects in the northern part of the Netherlands, largely concentrated around the so-called Eemshaven. Projects involved are large scale power stations and petrochemical plants.
11. The **Alberta Provincial Government** in Canada announced in July 2008 a CCS fund of C\$2 billion for large scale CCS implementation, from capture to storage (“cradle to grave”). Of the initial 54 applicants, 20 were invited to submit full proposals by the end of March 2009. Ten applications were submitted by the deadline. Three to five CCS operations will be funded (will be announced in 2009), with the requirement to store at least 5 Mt CO₂ by the end of the funding period in March 2015.
12. The **Canadian Federal Government** announced in its January 2009 budget the establishment of a fund of C\$850 million over five years for large-scale CCS demonstration projects.

2.5. R&D Components in CSLF Member Countries

Australia

CCS activities in Australia currently include pilot, demonstration, and commercial scale projects at various stages of implementation; finalisation of legislation and regulations for CO₂ storage; and various state, federal and international programmes and funds to accelerate CCS deployment.

Australian Federal and State government commitments to CCS include:

- The Global Carbon Capture and Storage Institute (GCCSI). In April 2009, the Prime Minister launched the GCCSI, the purpose of which is to accelerate the deployment of commercial scale CCS projects worldwide, and to which Australia has committed up to A\$100 million per year;
- Legislation - the Australian Federal Government and most State Governments have passed or are in the process of finalising legislation and regulations enabling geological storage of CO₂ both offshore and onshore Australia;

- Release of offshore areas for GHG storage. In March 2009, the Federal Government released the first ten offshore areas ever offered for commercial geological GHG storage;
- A\$2.4 billion announced in the 2009-2010 federal budget for low emissions coal technologies including new funding of A\$2 billion for industrial-scale CCS projects under the Carbon Capture and Storage Flagships programme;
- A\$600 million committed or allocated to date for CCS pilot and demonstration projects around Australia from the Low Emission Technology Demonstration Fund and National Low Emission Coal Initiative programs. Many of these projects also share in greater than A\$400 million of state government funding and other industry funding;
- Around A\$1 billion from State Governments to low emissions technology and climate change funds and other state-based programs;
- A\$165 million of Federal support for programmes including the National Carbon Mapping & Infrastructure Plan, National Coal Research Program, Carbon Storage Initiative and other studies, plus funding for international partnership programmes such as the Asia Pacific Partnership on Clean Development and Climate; and
- The development of a national emissions trading scheme, due to be implemented in 2011.

Canada

The Federal Government of Canada recently awarded funding to several CCS R&D Projects. The C\$230-million ecoENERGY Technology initiative was launched in 2007 to support the development of technologies to increase Canada's supply of clean energy, reduce energy waste, and reduce the environmental impact of the production and use of conventional energy. The following projects are funded to the tune of C\$140 million.

The Heartland Area Redwater Project (HARP) led by the Alberta Research Council (<http://www.arc.ab.ca/>) is designed to demonstrate the feasibility of safe CO₂ storage in the Redwater Leduc Reef, situated northeast of Edmonton, Alberta.

The Integrated Carbon Capture and Enhanced Oil Recovery Project, led by Enhance Energy (<http://www.enhanceenergy.com/>), involves the capture of CO₂ emissions from industrial sites in the Alberta Industrial Heartland. The captured CO₂ will be transported to mature oil reservoirs in central Alberta for EOR purposes and permanent sequestration.

The Fort Nelson Exploratory Project led by Spectra Energy Transmission (<http://www.spectraenergy.com/>) represents the first phase of research toward a world-scale carbon capture and storage project associated with Spectra Energy's existing gas processing plant in Fort Nelson, British Columbia. Raw natural gas contains high levels of CO₂, which processing strips away. If proven feasible, the CO₂ would be compressed, dehydrated, cooled into a concentrated stream and then injected into deep saline formations more than 2km underground for permanent sequestration.

Pioneer Project, led by TransAlta (<http://www.transalta.com/>), is a large-scale carbon capture and storage project proposed for the Keephills Thermal Electric Power Generation Plant.

The Belle Plaine Integrated Polygeneration CCS Project lead by TransCanada (<http://www.transcanada.com/>) proposes to conduct pre-front end engineering and design as a prerequisite to a decision to go forward with a C\$5-billion project to build and commission a polygeneration facility in Belle Plaine, Saskatchewan.

Husky Energy Inc. (<http://www.huskyenergy.ca/>) will focus on targeted R&D activities to develop new knowledge and methods for EOR in heavy oil reservoirs, using injected CO₂ permanently stored in the reservoirs, a new approach in heavy oil extraction.

The Alberta Saline Aquifer Project (ASAP)/Genesee Post-Combustion Demonstration Plant led by Enbridge (<http://www.enbridge.com/>) and EPCOR (<http://www.epcor.ca>). EPCOR's Genesee Post-Combustion Demonstration Plant involves the construction of a demonstration facility that will capture CO₂ from a greenfield coal-fired power plant (150 MW net) in Alberta. The captured CO₂ will be transported through collaboration with Enbridge and the Alberta Saline Aquifer Project (ASAP).

Denmark

A study for planning a pilot project for CO₂ EOR in a Danish oilfield has been initiated. The project is supported by the Danish High-Technology Foundation, and led by DONG Energy. Studies on modelling of oxy-fuel combustion are ongoing at Aalborg University and the Technical University of Denmark. The Geological Survey of Denmark and Greenland GEUS are involved in several international projects on CCS (<http://www.geus.dk/co2>). In the CESAR project, the pilot CO₂ capture plant (established as part of the CASTOR project) at the Danish power station Esbjergværket will be used to test more effective solvents. Denmark supports the IEA Greenhouse Gas R&D programme, and thus supports the CCS activities in this programme.

European Union

The 7th Framework Programme (FP7) is the main instrument at the disposal of the European Commission to support research, technology development, and demonstration in strategically important areas. Clean coal technologies and CCS are top priorities in FP7. The main objectives are increasing the efficiency of fossil fuel-fired power plants, decreasing the cost of CO₂ capture and storage, as well as proving the long-term stability, safety, and reliability of CO₂ storage. For the near future, the CCS Work Programme foresees in particular the research needed in support of large scale demonstration programmes in the domain of CCS.

In the revised EU ETS (Emission Trading System) directive, adopted by Parliament and Council in December 2008, 300 million allowances have been reserved, until 2015, for the support of large scale demonstration projects in the areas of CCS and innovative renewables. These will support industrial scale energy demonstration projects, costing hundreds of millions of Euros per project.

In addition to this, the “recovery package” put forward by the Commission (still to be voted by the Parliament) proposes to set aside €1.05 billion to support up to seven demonstration projects in seven Member States (six power plants and 1 infrastructure project).

France

ANR “CO₂ Program” (National Research Agency) (<http://www.agence-nationale-recherche.fr/EDEUK>) aims to improve production processes to generate nearly pure flows of CO₂ at lower cost and to devise methods for the storage of CO₂, particularly in deep geological formations. From 2005 to 2008, ANR supported 33 CCS projects for a total amount of €27 million. The call for projects is open to public-private partnerships on five thematic areas:

- Capture and transportation;
- Storage and MMV;
- Risk assessment, safety criteria, regulations;
- Breakthrough technologies for CO₂ capture; and
- Social, economical, and environmental evaluations

ADEME (French Environment and Energy Management Agency) (<http://www.dr6.cnrs.fr/SPV/spip.php?article73>) supports initiatives concerning CO₂ capture and storage and devotes special attention to energy efficiency, socio-economic issues, and environmental impacts. Since 2002, ADEME invested more than €5 million to support R&D projects. The conclusions of the “Grenelle de l’Environnement” in December 2007 led to a proposal to create dedicated “demo funds” of €100 million on CCS projects, managed by ADEME. This research aims to validate technologies that are still in their development stage. The priority research areas relate to capture by post-combustion or oxyfuel combustion, the demonstration of a localised transport infrastructure, and storage in deep saline formations. The research will support demonstration plants that are one-tenth the size of full scale industrial plants for two to three years.

Germany

The COORETEC (CO₂-Reduction-Technologies) programme of the Federal Ministry of Economics and Technology is part of the energy research programme of the Federal Government. The principal goal is the development of technologies to mitigate CO₂-emissions from power plants based on fossil fuels. Besides efforts to increase the efficiency of these power plants, the CO₂ capture is a major topic. CCS projects are oriented towards a large scale demonstration in 2014/15 and the availability of the technology in 2020. Collaborative research projects between science and industry are in the focus of the COORETEC programme. In the period 2004–2008, nearly 240 projects, with an amount of more than €124 million project funding, have been approved.

The GEOTECHNOLOGIEN-Programme (CO₂-Storage) of the Federal Ministry of Education and Research targets R&D-funding on basic research as well as on large field experiments focussed on CO₂-storage. Objectives are the development of technologies that enable safe and permanent storage as well as long-term and reliable monitoring. Furthermore, projects are oriented towards a large-scale demonstration. Collaborative research projects between science and industry comprise the focus of the GEOTECHNOLOGIEN-Programme. For the period 2005–2011, 24 projects, with an amount of more than €50 million project funding, have been approved.

Japan

R&D activities on CCS started in late 1980s which include various storage options (i.e., ocean storage, ECBM, and geological storage). R&D on capture includes chemical absorption, membrane, and oxyfuel. After the successful geological storage experiment in Nagaoka and preliminary evaluation of storage potential, the priority of R&D has been shifted to “sub-seabed” geological storage.

The current R&D projects under the Ministry of Economy, Trade, and Industry (METI) focus on development of safety assessment methodologies and supporting basic studies to facilitate CCS implementation. Also, in response to a G8 recommendation, an implementing body was established in May 2008 with investment by 29 private companies. Research organizations and industries are carrying out extensive engineering studies for large scale demonstration and full scale deployment of CCS.

Additionally, as a responsible permitting authority under the Marine Pollution Prevention Law, which was amended to include sub-seabed CO₂ storage, the Ministry of Environment has launched a project to develop the environmental impact assessment and monitoring protocols.

Korea

The Ministry of Education, Science & Technology (MEST) is responsible for administering the 10-year Carbon Dioxide Reduction & Sequestration (CDRS) program established in 2002

(www.cdrs.re.kr). The 3rd Phase of the CDRS program was launched in 2008 with a budget of US\$20 million for CCS. The program has mainly focused on developing breakthrough and novel CO₂ capture technologies such as dry sorbent CO₂ capture, ammonia absorption, membranes, and oxyfuel combustion. Dry sorbent CO₂ capture technology for post combustion developed by KIER and KEPRI has shown excellent performance in 25 kW fluidised bed CO₂ capture process and is currently being scaled up to 0.5 MW, slip-streamed from 500 MW Hadong coal-fired Power Plant.

The Ministry of Knowledge Economy (MKE) through KETEP (www.ketep.re.kr) has supported several CO₂ capture technologies including post-, pre-combustion and oxy-fuel combustion since 2006. These programs focus on the demonstration of CO₂ capture technology from a few MW to 300 MW until 2017 and are being implemented in cooperation with R&D institutes, the power industry, universities, and heavy industry, led by KEPRI (Korea Electric Power Research Institute). 2009-2012 government funding is about US\$170 million.

The Ministry of Land, Transport and Maritime Affairs and the Ministry of Knowledge Economy also supporting the assessment and examination of the CO₂ geological storage capacity estimation in Korean offshore and onshore geological formations.

Netherlands

The CATO (Carbon Capture, Transport and Storage) R&D programme is implemented by a strong consortium of Dutch companies, research institutions, universities and environmental organisations, led by the Utrecht Centre for Energy Research (UCE). Given its size, €25.4 million, the CATO programme can be regarded as the national research programme on CCS in the Netherlands. The Dutch government supports CATO with €12.7 million through the BSIK subsidy programme, managed by SenterNovem. CATO runs from 2004 until the end of 2008. This programme will be followed shortly by a second step in parallel to the CCS pilot en demo plants; foreseen budget is €90 million. (<http://www.co2-cato.nl/>)

CAPTECH, is a research programme of six Dutch consortium partners. The programme runs from 2006 until 2009 and is coordinated by ECN. The aim of the consortium is the qualification of CO₂ capture technologies with power plant efficiency losses less than 5% points, resulting in capture costs not higher than 20 to 30 €/tonne of CO₂ depending on fuel type. The budget of the programme is €2.5 million per year, and is financially supported by Dutch government (EOS). (<http://www.co2-captech.nl/>)

Norway

The Norwegian R&D&D program CLIMIT is run in collaboration between Gassnova and the Research Council of Norway. The annual budget from the Norwegian Government is approx. US\$10 million for R&D and US\$12 million for demonstration. The program covers the full CCS chain with capture, capture, and storage of CO₂ from fossil-based power production. A major project is the SOLVit project, where Aker Clean Carbon in collaboration with SINTEF is developing new solvents and absorption processes for CO₂ capture. Recently, two centres for environmentally friendly energy technology within CCS have been established, with annual budgets from the government of US\$4.5 million.

Saudi Arabia

Saudi Arabia developed a comprehensive carbon management roadmap with CCS and CO₂ EOR R&D as major components. Other components include technology development of CO₂ capture from fixed and mobile sources, and CO₂ industrial applications. The roadmap seeks to contribute to the global R&D efforts in reducing greenhouse gas emissions through the development of technological

solutions that lead to sustainable reductions in CO₂ levels in the atmosphere. These R&D activities are pursued through different R&D centres, and universities such as King Abdullah University of Science and Technology (KAUST), King Abdullah Petroleum Studies and Research Centre (KAPSARC), with Saudi Aramco having a strong leadership role in advancing these technologies.

A pilot CO₂ storage is planned as part of CO₂-EOR demonstration project. In addition, a CO₂ storage atlas will be produced.

South Africa

South Africa is investigating CCS as a green-house gas emission mitigation measure as a transition measure until renewable and nuclear energies can play a greater part in the South African energy economy. In order to develop capacity, both human and technical, in this relatively new field, a Centre for Carbon Capture and Storage commenced operations 30 March, 2009 within the South African National Energy Research Institute. The Centre is a private/ international/ public partnership and financed from local industry, SANERI, government, and international sources. Thus far, ZAR25 million has been raised for the first five years of the research programme.

The vision of the Centre is that a carbon capture and storage demonstration plant will be operational in South Africa by the year 2020, which requires development of country human and technical capacity. A test injection is scheduled for completion in 2016.

United States

The U.S. Department of Energy's Fossil Energy Program is working to ensure that cost-effective, near-zero emission coal power plants equipped with CCS will be available to meet world energy demand in the future. The U.S. program has appropriated US\$692 million dollars in FY2009 to support the development and demonstration of innovative technologies critical to coal systems with CCS including pre- and post-combustion capture processes; advanced gasification systems; hydrogen turbines; fuel cells; high strength materials and sensors; CO₂ capture and compression technologies; and others. More mature CCS technologies are demonstrated at commercial scale through DOE's Large-Scale Demonstration programs. DOE's seven Regional Carbon Sequestration Partnerships (RCSPs) are each conducting large-scale CO₂ injection tests (up to 1 million tons per year), to validate the potential for safe and permanent geologic storage. In addition, the American Reinvestment and Recovery Act (ARRA) of 2009 provides an additional US\$3.4 billion for CCS activities. <http://www.fe.doe.gov>

MODULE 3: GAP IDENTIFICATION

The ultimate objective of CO₂ capture and storage R&D and demonstration activity is the development of safe and cost-effective processes for the capture, transport, and long-term storage of CO₂ to mitigate climate change impacts. In this module, this broad objective is broken down into a number of more specific goals with respect to each particular technology. This is followed by a discussion of the gaps between current capabilities and what action would be required to meet these goals.

3.1. The Need for New/Improved Technology

Much of the current implementation of CCS is occurring in the natural gas industry where separation of CO₂ from the gas stream is required for commercial reasons and the incremental cost of capture and storage is relatively small. Wider implementation into power generation and other industries will require appropriate drivers such as:

- Emission regulations or incentives to limit the discharge of CO₂ to the atmosphere; and
- Cost reductions and/or appropriate financial incentives to reduce the financial burden of CO₂ capture and storage.

CO₂ capture is currently the most costly component of CCS. Significant process efficiency penalties are associated with capture which adds to financial pressures associated with CCS. While incremental reductions in capture costs are certainly possible, it is necessary to discover whether large cost savings are possible with this relatively mature technology. If not, different plant configurations, separation technologies, or more radical approaches to the capture of CO₂ will be needed to accelerate deployment.

Relative to CO₂ capture, transmission costs are low and the technology problems are reasonably well understood. High pressure pipelines and/or ship tankers are the preferred modes of transportation of CO₂ in compressed liquid form. Transmission costs are, of course, distance dependent so the emission source should be located in close proximity to a storage site wherever possible. There is limited need for new technology in this area, although few, if any, tankers of the necessary capacity and fitness for purpose exist. In contrast, the sheer scope of creating major CO₂ pipeline transmission systems, some of which are likely to be located in populated areas, will raise legal, institutional, and regulatory issues as well as public concerns.

The largest capacity for CO₂ storage is in geological formations: deep saline formations, and depleted oil and gas reservoirs. The primary issues are the difficulty of quantifying actual storage capacity, long-term security, verifiability, and the environmental impact of storage.

Increased knowledge of the geology and geochemistry of proposed storage sites is needed. Improved monitoring and modelling techniques are necessary to verify storage, both for emissions trading and national accounting uses, and to prove long-term storage security. The environmental impact and safety of CO₂ storage requires better understanding. Monitoring of naturally occurring CO₂ accumulations can provide information on levels of seepage and the very long-term behaviour of CO₂ in geological formations. It is necessary to demonstrate CO₂ capture and storage in several large-scale projects in order to optimise the technology and reduce costs, to establish expertise and industrial capability for the manufacture and installation of the plants, and to develop best practice guidelines.

Regulatory frameworks will also influence technical decisions. For example, state or provincial, national, regional, and international laws and regulations will determine whether CO₂ is classified as a waste or not, whether impurities are acceptable in the stored CO₂ and whether international

conventions, such as the London Convention on the Prevention of Marine Pollution by Dumping of Wastes and Other Matter (1972), should be amended to take climate change into account, as this problem was not envisaged at the time the conventions were framed (International Maritime Organisation, 2008).

Concerning the possible economies in the field of storage, a decrease in the drilling and casing price would have an unquestionable impact on the storage cost. Improvements in the cost effectiveness of drilling, which may issue from geothermal or mining activities, should be analysed.

In view of the expectation of permanent CO₂ storage, the potential liability must be understood so that long-term plans and appropriate levels of monitoring can be put in place. Public awareness and acceptance, particularly near project sites, must be increased as public attitudes are a key factor influencing politicians and regulators.

Summary of key technological needs to assure widespread deployment:

1. Demonstrate, by 2020, fully-integrated industrial-scale CCS projects
2. Reduce CO₂ capture cost, efficiency penalties, and transport infrastructure costs (CCS needs to compete cost wise with other climate change strategies such as increased use of renewables)
3. Validate effectiveness of monitoring for safety, long-term security, environmental impact and verification
4. Establish applicable sets of operational guidelines for more accurate geological surveys and for injection/measurement/mitigation techniques
5. Create the ability to optimize transport infrastructures to accept CO₂ from different sources

3.2. Technology Gaps

3.2.1. CO₂ Capture Gaps

Different capture technologies pose different technical challenges requiring unique solutions. Common to all technologies is the need to reduce costs and reduce the efficiency penalties associated with capture systems.

3.2.1.1. Post-combustion capture

The applicable technology for post-combustion capture is widely deployed in chemical processing. However, the gaps lie in transferring the technology to CCS specific applications, optimising capture systems for generation plant and industrial processes, and addressing the economics of the capture process including the cost and performance of solvents.

Priority activities:

- Develop better solvents for CO₂ capture
- Identify optimal capture process designs and ways of integrating the capture systems with power stations to reduce energy loss and environmental impact
- Build understanding of both organic and inorganic non-precipitating absorption systems supported by pilot scale data (2–4 MW) for a selection of the most promising
- Identify advantages and limitations of precipitating systems (e.g., carbonates)
- Develop better understanding of the assessment of environmental impacts of capture technologies

3.2.1.2. Oxy-fuel

This technology is already used on an industrial scale but is currently very costly when applied to CCS. In order to address this key gap, priority activities should focus on technological advances, specifically in material science and in process engineering, that will reduce this cost and improve performance and reliability.

Priority activities:

- Develop high temperature turbines for gas-fired and fuel oil oxyfuels
- Develop CO₂/N₂ separation technology for industrial processes — blast furnaces
- Undertake R&D on material selections
- Research into CO₂ capture, compression, and conditioning processes for oxy-fuel combustion
- Research into the economics and technical issues for the adaptation of cryogenic air separation units (ASU) in oxy-fuel power stations

3.2.1.3. Pre-combustion capture

Integrated Gasification Combined Cycle (IGCC) is the leading technology for pre-combustion capture. As an amalgam of several technologies, gaps exist in the effective integration of the key component technologies.

Priority activities:

- Undertake research into full process integration and optimization of the components for power station applications
- Develop better systems for coal and residual liquid petroleum fuels gasification (e.g., higher efficiency shift processes), natural gas reformer, and syngas cooler
- Improve CO₂ separation and capture technologies
- Develop high efficiency and low emission H₂ gas turbines

3.2.1.4. Emerging and new concepts for CO₂ capture

The emphasis here is on long-term exploratory R&D in advanced and innovative concepts for the next-generation of CO₂ capture technologies.

Priority activities:

- Conduct research in the following capture technologies:
 - Chemical looping
 - Post-combustion carbonate looping cycles
 - Gas separation membranes and adsorption processes for CO₂
 - Ion-transport membranes for O₂ separation

3.2.1.5. Improvements in generation efficiency

Recognising that CO₂ capture and compression equipment significantly reduces the available electrical energy output, there is a great need to improve power station efficiency. This is to reduce as far as possible the impacts of the additional plant loads due to capture technologies. Efficiency improvements extend to the design and integration of the CO₂ compression systems. Greater use can also be made of biomass cofiring which can give apparent negative emissions due to the way biomass is regarded under greenhouse accounting rules.

Priority activities:

- Support initiatives to improve efficiency of electricity generation plant
- Develop high efficiency gas turbines and support new cycle concepts
- Develop alternative power generation processes that have the potential to produce improved economics when paired with absorption capture

3.2.2. CO₂ Transport Gaps

Transportation is the crucial link between CO₂ emission sources and storage sites. CO₂ is likely to be transported predominantly via pipelines which will present different regulatory, access and development challenges for different regions of the globe where CCS is to be implemented.

The key knowledge gaps are associated with standards for material selection for CO₂ streams where significant levels of impurities and condensables may exist, safety standards for pipelines, and suitable alternatives such as mobile transport systems. There are also other significant non-technology issues such as the economic and regulatory issues with establishing networks in dense population centres.

Priority activities:
<ul style="list-style-type: none"> • Conduct cost benefit analysis and modelling of CO₂ pipeline networks and transport systems for tankers and trucks • Develop tanker transport of liquid CO₂ • Develop detailed specification with respect to the impurities present from various processes (power station, refineries, industry), which are not present in current CO₂ production units • Improve dispersion modelling and safety analysis for incidental release of larger quantities of CO₂ from the transport system (e.g., CO₂ pipeline, CO₂ ship, or intermediate storage tank at harbor) • Develop proper mitigation measures and design, to ensure safe establishment and operation of CO₂ pipelines through urban areas • Identify and define proper safety protocols to protect CO₂ pipelines, including response and remediation • Identify regulations and standards that need addition or updating for CO₂ transportation (e.g., existing regulations for natural gas pipelines)

3.2.3. CO₂ Storage Gaps

As discussed in section 1.3, CO₂ can be stored in several types of geological settings, including deep saline formations, depleted oil and gas fields, and deep unmineable coal seams. For CCS to be widely available for industrial-scale deployment by 2020, there is an urgent need to demonstrate to governments, the public, regulators, and industry that there is sufficient storage capacity available for large-scale CO₂ projects in various parts of the world and that very large quantities of CO₂ (1–10 Mt/a CO₂ or more per project) can be stored safely for millennia. This requirement applies particularly to deep saline formations and unmineable coal beds, as the storage capacity of oil and gas fields is relatively well defined and understood through oil and gas exploration and production.

Priority activities for all geological storage types:
<ul style="list-style-type: none"> • Develop best practice guidelines for storage site selection, operation and closure, including risk assessment and response and remediation plans in case of leakage • Develop appropriate models to predict the fate and effects of the injected CO₂ (multi-phase fluid flow, thermo-mechanical-chemical effects and feedback), including leakage • Research the impact of the quality of CO₂ (that is, purity of CO₂ and effects of other compounds) on interactions with the formation, brine, and storage behaviour • Monitor impacts (if any) on the environment • Assess long-term site security post-injection including verified mathematical models of storage • Compile baseline surveys for measurement, monitoring and verification (MMV) activities including site-specific information on CO₂ background concentration and seismic activity • Develop instruments capable of measuring CO₂ levels close to background and to distinguish between CO₂ from natural processes and that from storage • Define methods for the production and disposal of brine from saline formations as a result of CO₂ injection • Address costs associated with storage, especially drilling and establishing wells

Specific priorities follow.

3.2.3.1. *Deep saline formations*

While deep saline formations are thought to have the largest potential capacity for CO₂ storage, better understanding of their storage capacity and geological, geomechanical and geochemical properties is required. Specific gaps include a lack of regional and site-specific knowledge about:

- The thickness and stability of the cap rock (its sealing potential);
- Reservoir formation depth, volume, and characteristics including storage capacity;
- Trapping mechanisms and efficiency of storage;
- Long-term lateral transport and fate of brine (and consequently the CO₂), including pressure control and variation;
- CO₂ migration pathways and timeframes, and determining the volume of rock accessed by a migrating plume;
- The rate and effect of geochemical interactions between CO₂ and the reservoir formation mineralogy and fluids;
- Pressure building in the storage formation — consequences on storage capacity and on other activities using the same aquifer; and
- Remediation actions in case of diffuse CO₂ leakage far from the injection point or pollution of surrounding aquifers.

Priority activities:
<ul style="list-style-type: none"> • Conduct a comprehensive assessment of worldwide capacity for CO₂ storage in various geological settings but particularly deep saline formations that: <ul style="list-style-type: none"> – Applies consistent methodology for storage capacity estimation – Compiles, collates, and integrates existing aquifer capacity data from world-wide projects – Provides a robust storage capacity classification system and informs the legal end of storage licensing procedures • Increase geological knowledge and process modelling performance that: <ul style="list-style-type: none"> – Further investigates the key reservoir and cap rock characteristics of deep saline formations relevant to storage injectivity, capacity and integrity (geometry, structure, mineralogy, fluid chemistry, petrophysics, hydrodynamics, geomechanics and so on) – Provides tools for predicting spatial reservoir and cap rock characteristics, with assessment of uncertainties – Provides a robust storage capacity classification system and informs the legal end of storage licensing procedures • Produce a digital (GIS or 3D modelling package) world CO₂ storage atlas to cover all major geological storage types

3.2.3.2. *Depleted oil and gas fields*

Additional understanding of the geochemical reactions between CO₂ and the geological formation is required. The initial security of reservoirs (implicitly guaranteed by the presence of oil and/or gas) may be compromised in the near well area by drilling, acid treatment, and fracturing during production. The integrity of abandoned wells (particularly very old or unknown wells) can be adversely affected by corrosion of the well casing and improper cementing, leading to leakage of CO₂ out of the formation. Over-pressurisation of the reservoir must be avoided in case existing faults are reactivated or new faults are created and the rate of injection adjusted and constantly monitored.

For depleted oil and gas fields, storage projects require site-specific evaluation of reservoirs and seals to identify and quantify damage caused during hydrocarbon extraction and the status of existing, sealed, or abandoned boreholes.

Priority activities:

- Develop best practice site selection and assessment guidelines
- Develop an inventory of oil and gas fields with large storage capacity
- Assess the condition of existing wells and remediation technologies

3.2.3.3. *Unmineable coal seams*

The major knowledge gaps surrounding CO₂ storage in unmineable coal seams relate to coal properties including the permeability of certain coal types and the behaviour of coals in the presence of CO₂. Methods for improving the permeability of coals, such as the effectiveness and costs associated with fracturing, need to be assessed. Equally important is the realisation that the resource will be sterilised once it is used as a CO₂ sink.

Priority activities:

- Assess worldwide storage capacity in unmineable coal seams
- Research CO₂-coal interactions, especially with respect to the mechanisms of methane displacement and permeability decreases

3.2.3.4. *Mineral Carbonation*

Mineral carbonation provides a permanent CO₂ storage option. Large quantities of olivine and serpentine rock are found in certain parts of the world, in sufficient quantity to provide large CO₂ storage capacity. Knowledge gaps are associated with the process for converting captured CO₂ into a mineral, for example, increases in the rate of reaction needed for practical storage. The environmental impacts of large-scale disposal of solid material also need to be examined.

Priority activities:

- Build on pioneer studies to further investigate the possibilities of enhancing mineral trapping of CO₂ and impurities in specific types of settings (basaltic and ultramafic aquifers, highly saline aquifers, geothermal reservoirs, etc.) and map these
- Study thermodynamics and kinetics of chemical and microbiological reactions, as well as impacts on fluid flow, injectivity, and geomechanics
- Carry out a techno-economical feasibility study relating to mineral storage of CO₂

3.2.4. **Gaps in Uses of CO₂ (EOR and EGR)**

EOR, because of the economic benefit of the produced oil, provides the best practical near-term potential for CO₂ storage. Current practices, however, are optimised for oil recovery rather than CO₂ storage and the injected CO₂ at the end of the EOR period is recovered and recycled in subsequent EOR projects. Hence, successful EOR-related CO₂ storage projects need to place equal emphasis on storage and oil recovery. The concept of enhanced recovery of gas (EGR) needs to be proven and shown to be beneficial in practice.

Enhanced coal bed methane (ECBM) production provides the opportunity for economic return in conjunction with CO₂ storage in coals. While it is known that CO₂ injection will cause the displacement of methane and its replacement with CO₂, greater understanding of the displacement mechanism is needed to optimise CO₂ storage and to understand the problem of decreased permeability of coals in the presence of CO₂ (see suggested project areas in 3.2.3.3.).

3.2.5. **Gaps in Security of Geologic Storage**

Site characterisation and monitoring prior to storage, during injection, and following injection are vitally important. The condition of existing boreholes and their integrity (in terms of sealing /

leakage) in the presence of CO₂ must be surveyed. Extensive tests to define the volume of the reservoir formation, the thickness and integrity of the cap rock and the character of any existing faults are desirable prior to injection. For monitoring and verification purposes, background information on CO₂ concentrations at ground level, both offshore and onshore, is needed as well as background information on seismic activity in the area.

During injection, the storage site should be fully instrumented to measure reservoir pressure and to detect any escape of CO₂. Fail-safe procedures, perhaps involving CO₂ venting, must be available in the event of over-pressurisation. Methods of monitoring must be sufficiently sensitive to detect CO₂ concentrations only slightly above the background level, and at low leakage rates (approaching less than 0.1% per year). On land, the analysis must be able to distinguish between ground level CO₂ associated with natural processes such as the decay of plant life and that originating from CO₂ injection. Seismic activity should be monitored and compared to background levels.

The extent to which the monitoring capability must remain in place after injection ends and the form of monitoring required are matters to be determined. Detailed, verified mathematical models will be important, especially during the post-injection period. Measuring leakage rates and migration of the CO₂ is important, not only from a safety and environmental point of view, but also to verify emission trading contracts and to provide evidence in legal disputes. All of these developments must recognise the length of time for which secure storage is required.

Risk assessment will play an important role at all stages of activity, not only for planning and when seeking approval for such projects but also in preparing for the post-injection period. Risk assessment techniques must be further developed and verified, which will require more field data, especially from monitored storage projects.

Priority activities:
<ul style="list-style-type: none">• Model the fate and effects of injected or leaked CO₂• Develop best practice guidelines on how to characterize and monitor a site prior to, during, and after storage• Build tools that can be used to characterise a potential storage site• Develop low cost and sensitive CO₂ monitoring technologies• Construct maximum impact procedures and guidelines for dealing with CO₂ leaks• Create risk assessment tools to identify the likelihood and consequence of CO₂ leaks and inform effective decision making

3.2.6. CCS Integration Gaps

To facilitate the broad integration of CCS in new and retrofitted energy plants it is necessary to gain experience and information by conducting multiple large-scale demonstrations, such as called for by the G8 goal of developing 20 demonstration projects by 2020. Currently, insufficient information exists on the design, cost, and space requirements, operation, and integration of CCS with energy facilities. This lack of information impedes making power stations and industrial plants CCS-ready for when CCS technology achieves commercial status. In addition to gaining the needed experience and information from implementing demonstration projects, it is crucial that pertinent available information be made available to the world community and that needed follow-up R&D stemming from the demonstration projects be identified and undertaken. The CSLF is uniquely positioned to achieve these goals.

Priority activities:
<ul style="list-style-type: none"> • Identify reliable sources of information and data related to the design, cost, and space requirements, operation, and integration of CCS with energy facilities • Conduct periodic technical reviews of all aspects of recognized large-scale CCS demonstration projects and report on the “lessons learned” • On a periodic basis, update the Technology Roadmap to include technology gaps identified during the technical assessment of demonstration projects • Integrate with existing infrastructure

3.3. Summary of Key Technology Needs and Gaps

ELEMENT	NEED	GAPS
Capture	Reduce CO ₂ capture cost and efficiency penalties	<ul style="list-style-type: none"> • Alternative absorption solvents or materials that reduce capture costs and increase energy efficiency compared with amine-based systems • Alternative power generation processes that have the potential to produce improved economics compared with absorption capture • Improve generation efficiency and capture penalties and cost reductions will follow
Transport	Create the ability to optimise transport infrastructure to accept CO ₂ from different sources; reduce transport infrastructure costs	<ul style="list-style-type: none"> • Understanding of the effects of CO₂ impurities on CO₂ transport • Modelling capability, including compression and optimisation to improve issues relating to the transport network of CO₂ between sources and potential sinks • Response and remediation procedures developed in advance of the possibility of CO₂ pipeline accidents
Storage	Demonstrate sufficiency of CO ₂ storage capacity; validate monitoring for safety, long-term security, environmental impact and verification	<ul style="list-style-type: none"> • Comprehensive national and global CO₂ storage atlases (e.g., GIS-based) of suitable geological formations with information on emission sources and other relevant details • Understanding of CO₂ storage capacity and geological, geomechanical and geochemical properties of deep saline formations • Understanding CO₂-coal interactions, especially with respect to the mechanisms of methane displacement and permeability changes • Understanding the effect of impurities in the CO₂ stream on the capacity, safety and security of CO₂ storage • Site-specific information on CO₂ background concentration and seismic activity • Capability of ensuring long-term site security post-injection including verified mathematical models of storage and risk assessment tools • Development of instruments and methodologies capable of discriminating between CO₂ from natural processes and that from storage • Best practice guidelines for storage site selection, operation and closure, including risk assessment

ELEMENT	NEED	GAPS
		<ul style="list-style-type: none"> • Site-specific evaluation of reservoirs and oil/gas fields to identify damage due to hydrocarbon extraction and status of sealed boreholes • Development of response and remediation plans on a site-specific basis prior to injection • Brine displacement/management
Integration	Demonstrate 20 fully-integrated commercial-scale CCS projects by 2020 with agreements on quantum of projects and definition of size/scale.	<ul style="list-style-type: none"> • Experience and information on the design, cost, operation, and integration of CCS with energy facilities and industrial processes • Consistent knowledge sharing between demonstration projects • Integration of existing infrastructure
Cross-cutting issues		<ul style="list-style-type: none"> • Risk assessment tools and best practice guidelines • Environmental impacts of use of solvents in capture systems • Energy price issues would encourage the take-up of CCS

MODULE 4: TECHNOLOGY ROADMAP

4.1. The Role of the CSLF

The CSLF, consistent with its Charter, has catalysed the broad adoption and deployment of CCS technologies among participating countries. Since its establishment in 2003, many member countries have initiated significant CCS activities, and the CSLF will continue to promote the development of improved cost-effective technologies through information exchange and collaboration. The CSLF intends to enhance its ongoing and future activities to close the key CCS technology gaps highlighted in this Technology Roadmap through close collaboration with government, industry, key funding, and support organisations such as the Global Carbon Capture and Storage Institute and all sectors of the international research community.

4.2. Achieving Widespread CCS Deployment

This roadmap is intended to help set priorities for the CSLF by identifying key topics that need to be addressed to achieve the goal of wide-spread deployment of CCS. Module 1 has briefly described the current status of CO₂ capture and storage technologies. Module 2 has highlighted the global progress made on CCS and Module 3 has identified the needs and technology gaps to help guide this revision of the roadmap. Module 4 is the Technology Roadmap which has been updated to address the identified gaps.

The focus of the Technology Roadmap is on:

- Achieving commercial viability and integration of CO₂ capture, transport, and storage technologies;
- Developing an understanding of global storage potential, including matching CO₂ sources with potential storage sites and infrastructural needs;
- Addressing risk factors to increase confidence in the long-term effectiveness of CO₂ storage; and
- Building technical competence and confidence through sharing information and experience from multiple demonstrations.

Since the original Roadmap was developed in 2004 (Figure 15) significant activity and progress has been made in all aspects of CCS, resulting in successful completion of the early milestones identified in the timeframe 2004–2009. For example, there are now 20 recognised CSLF projects demonstrating worldwide collaboration on CCS and contributing to the CCS knowledge base. Much has been learned that allows the future path forward to a post-2020 timeframe to be identified. However there are still a number of important gaps that need to be addressed and where necessary, projects at the R&D, pilot, and large integrated project levels should be encouraged.

In all aspects, effective sharing of knowledge and lessons learned will be a key element that will contribute to the acceleration of deployment of CCS. To assist this, it will be beneficial to establish guidelines on the type and level of information to be shared that could be applied worldwide in accordance with applicable IP and other property rights. This would help to avoid problems with sharing of information between countries and regions and so undoubtedly facilitate the global take-up of CCS.

The updated Roadmap reflects those challenges that need to be addressed as well as milestones that need to be achieved in order to realise wide scale deployment of CCS post- 2020. It is summarised in Figure 16, which now encompasses two additional key issues: CCS integration and CO₂ transport infrastructure.

ELEMENT	NEED	2009–2013	2014–2020	Post–2020
Capture	Reduce CO ₂ capture cost and efficiency penalties	<ul style="list-style-type: none"> • Research and develop scalable low-cost capture technologies 	<ul style="list-style-type: none"> • Demonstrate at large-scale advanced, affordable capture systems • R&D on ongoing and emerging concepts 	<ul style="list-style-type: none"> • Commercial capture technologies available
Transport	Create the ability to optimise transport infrastructure to accept CO ₂ from different sources; reduce transport infrastructure costs	<ul style="list-style-type: none"> • Determine allowable CO₂ impurities on CO₂ transport • Establish models to optimise transport network of CO₂ between sources and potential sinks 	<ul style="list-style-type: none"> • Establish technical standards for trans-boundary CO₂ transport • Establish regional networks as examples of multiple source CO₂ transportation 	<ul style="list-style-type: none"> • Establish infrastructure emplacement for CO₂ transport
Storage	Demonstrate sufficiency of CO ₂ storage capacity; validate monitoring for safety, long-term security, environmental impact and verification	<ul style="list-style-type: none"> • Develop national and global atlas of CO₂ storage capacity • Establish methodologies for estimating site-specific and worldwide storage capacity • Establish methodologies for predicting the fate and effects of injected CO₂ and for risk assessment • Initiate large-scale field tests for injection and MMV • Establish industry best practices guidelines for reservoir selection, CO₂ injection, storage, and MMV 	<ul style="list-style-type: none"> • Refine global atlas of CO₂ storage capacity • Successfully complete large-scale field tests for validation of injection and MMV best practices for updating industry standards • Commercialise MMV technologies 	<ul style="list-style-type: none"> • Implement commercial operation of storage sites
Integration	Demonstrate, by 2020, fully-integrated commercial-scale CCS projects	<ul style="list-style-type: none"> • Initiate large-scale demonstration projects • Build CCS projects database 	<ul style="list-style-type: none"> • Establish operational experience and lessons learned with CCS • Demonstrate integrated next generation technologies • Conduct R&D based on lessons learned • Ongoing technology diffusion 	<ul style="list-style-type: none"> • Achieve commercial readiness

Figure 16. 2009 CSLF Technology Roadmap

4.3. CSLF Actions

Through its activities, engagement with members and the development of key resources such as this Roadmap, the CSLF has been instrumental in stressing the importance of CCS as an indispensable technology in a set of measures to address climate change. The support by governments, industry, and the general community for urgent measures is intensifying and there is a great need to implement large scale projects as soon as possible with wide deployment by the target date of 2020.

The CSLF encourages its members to pursue a number of high level initiatives and specific activities that are divided into project groupings. High level initiatives are associated with:

- Technology diffusion;
- Work to address the technological gaps and priorities that have been identified;
- Continuing to build capacity; and
- Ensuring that the appropriate level of resources is identified to fill these gaps.

Key among the project groupings is an increasing emphasis on:

- Initiating integrated, large scale, and commercial demonstration projects;
- Identifying, assessing, and preparing safe storage sites;
- Building best practice guidelines, standards, and methodologies and setting up information flows across all aspects of CO₂ capture, transport, storage, and integration; and
- Reducing the costs of capture through improved processes and research into alternatives.

While the technical challenges are appreciable, there are also major regulatory, financial, and community-perception hurdles for CCS to overcome in order for it to be widely deployed as soon as practical. The CSLF is not alone in confronting these vital, challenging tasks. In partnership with organisations such as the IEA and the GCCSI, the CSLF can marshal a range of resources to deploy critical technologies and to address these other barriers.

For the past decade, the CSLF has worked closely to advance the state of knowledge about CCS with the IEA, raising high-level awareness, conducting analysis, and sharing policy and legal best practices. As part of this cooperation, the CSLF provided key input into IEA publications, including *Legal Aspects of CO₂ Storage: Updates and Recommendations* (IEA, 2007) and *CO₂ Capture and Storage: A Key Carbon Abatement Option* (IEA, 2008).

This coordination continues with the CSLF and the IEA CCS Roadmap efforts, which complement one another. The CSLF Technology Roadmap has provided the main technical input into the IEA CCS Roadmap. The IEA CCS Roadmap will provide greater detail on global CO₂ reduction targets and the role of CCS, as well as set additional milestones for development of the necessary policy, legal, financial and public awareness frameworks to ensure successful CCS implementation around the world.

Figure 17 summarises the key milestones for the CSLF.

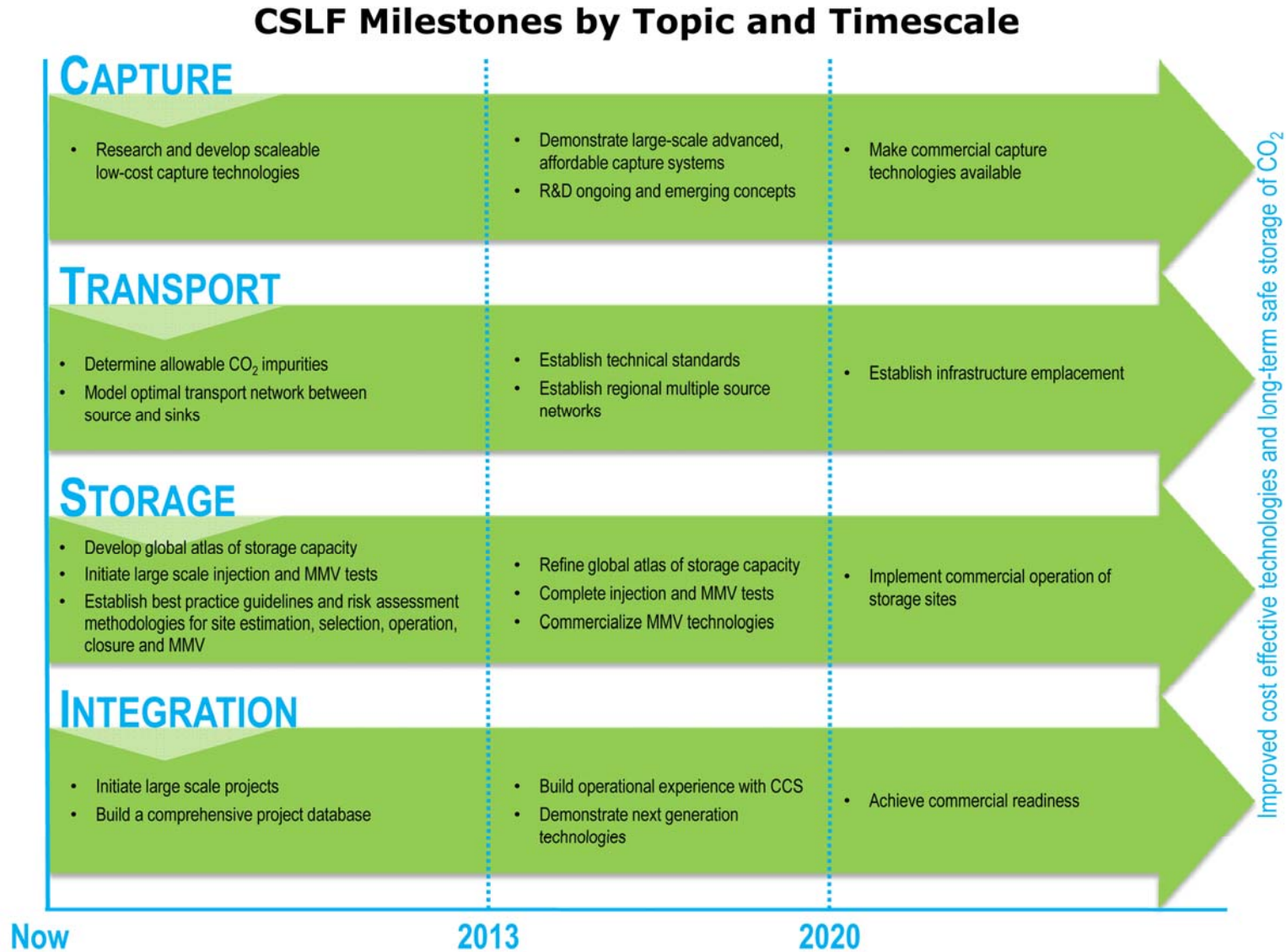

Figure 17. A summary of the key milestones and Technology Roadmap for the CSLF in 2009

4.4. Summary

This Roadmap has identified the current status of CCS technologies around the world, the increasing level of activity in the industry, the major technology needs and gaps, and the key milestones for the development of improved cost-effective technologies for the separation, capture, transport, and long-term storage of CO₂.

Implementation of national and international pilot and demonstration projects is seen as a critical component in the development of lower-cost, improved capture technologies and safe long-term storage.

CCS can play a critical role in tackling global climate change. In order for it to be an effective part of the solution, CCS must be demonstrated as soon as possible with wide deployment by the target date of 2020. It is essential to establish the technical foundation for affordable capture, transport, and safe and effective long-term geologic storage of CO₂ as quickly as possible.

The CSLF will continue to catalyse the deployment of CCS technologies by actively working with member countries, governments, industry, and all sectors of the international research community on the strategic priorities outlined in this Technology Roadmap. The CSLF will continue to work with existing and new support organisations, such as the Global Carbon Capture and Storage Institute, in order to efficiently utilise scarce world resources and effort and to ensure that key technology gaps are addressed.

References

1. Intergovernmental Panel on Climate Change (IPCC), *Special Report on Carbon Dioxide Capture and Storage*, 2005.
2. Intergovernmental Panel on Climate Change (IPCC), *Summary for Policymakers. In: Climate Change 2007: The Physical Science Basis (Contribution of Working Group I to the Fourth Assessment Report of the Intergovernmental Panel on Climate Change)*, 2007.
3. International Energy Agency Greenhouse Gas R&D Programme, *Capturing CO₂*, 2007.
4. International Maritime Organisation, http://www.imo.org/home.asp?topic_id=1488, 2009.
5. International Maritime Organisation, *1996 Protocol to the Convention on the Prevention of Marine Pollution by Dumping Wastes and Other Matter (London Protocol 1996)*, http://www.imo.org/includes/blastDataOnly.asp/data_id%3D17756/11.pdf, 2007.
6. McKinsey & Company, *Carbon Capture & Storage: Assessing the Economics*, 2008.
7. S. Miyazaki, I.H. Lavering, A.E. Stephenson and L. Pain, *Australian Petroleum Accumulations Report 6*. Department of Primary Industries and Energy, 1990.
8. Moritis, G., Special report: More US EOR projects start but EOR production continues to decline. *Oil and Gas Journal*, 106(15), April 21, 2008 p. 41-42 and 44-46.
9. National Energy Technology Laboratory (NETL), http://www.netl.doe.gov/publications/press/2007/070830-Regional_Partner_Launches_Drilling.html, 2009.
10. Petroleum Technology Research Centre, http://www.ptrc.ca/weyburn_overview.php, 2009.
11. StatoilHydro, <http://www.statoilhydro.com/en/technologyinnovation/protectingtheenvironment/carboncaptureandstorage/pages/captureandstorageofco2.aspx>, 2009.
12. The Organisation for Economic Co-operation and Development and International Energy Agency (OECD/IEA), *CO₂ Capture and Storage: A Key Carbon Abatement Action*, 2008.
13. The Global Energy Technology Strategy Program, *Carbon Dioxide Capture and Geological Storage: A Core Element of a Global Technology Strategy to Address Climate Change*, 2006.
14. The Cooperative Research Centre for Greenhouse Gas Technologies (CO₂CRC), <http://www.co2crc.com.au/>, 2009.
15. E. Tzimas, A. Georgakaki, C. Garcia Cortes, S.D. Petevs., *Enhanced Oil Recovery using Carbon Dioxide in the European Energy System*. European Commission Joint Research Centre. Report EUR 21895 EN. P30, 2005.
16. Vattenfall, http://www.vattenfall.com/www/co2_en/co2_en/Gemeinsame_Inhalte/DOCUMENT/388963co2x/578173repo/603971vatt/P0274210.pdf, 2009.

Glossary of Acronyms, Abbreviations, and Units

A\$	Australian dollars
C\$	Canadian dollars
CCS	Carbon capture and storage
CHP	Combined Heat and Power
CO ₂	Carbon Dioxide
CO ₂ CRC	Cooperative Research Centre for Greenhouse Gas Technologies
COE	Cost of energy
CSLF	Carbon Sequestration Leadership Forum
DOE	U.S. Department of Energy
ECBM	Enhanced coal bed methane
EGR	Enhanced gas recovery
EOR	Enhanced oil recovery
ETS	Emissions trading scheme
EU	European Union
GCCSI	Global Carbon Capture and Storage Institute
GIS	Geographic information system
Gt	gigatonnes, 10 ⁹ tonnes
IEA	International Energy Agency
IGCC	Integrated Gasification Combined-Cycle
IP	Intellectual property
IPCC	Intergovernmental Panel on Climate Change
KWh	kilowatt hour, unit of electrical energy
mg/L	milligrams per litre
LHV	Lower heating value
MPa	megapascals, SI unit of pressure (10 ⁶ pascals)
Mt/a	megatonnes per annum, millions of metric tons per year
MMV	Measurement, Monitoring and Verification
MW	megawatts, SI unit of power, subscript _{th} denotes thermal capacity, _e denotes electrical
NGCC	Natural Gas Combined Cycle (also referred to as CCGT – Combined Cycle Gas Turbine)
OECD	Organisation for Economic Co-operation and Development
PC	Pulverised Coal (sometimes referred to as PF – Pulverised Fuel)
R&D	Research and Development
US\$	U.S. Dollars

