

Capture Technologies and Costs

Howard Herzog
MIT

*Workshop on Capacity Building for
Carbon Capture & Storage (CCS)*

Pittsburgh, PA
May 7, 2007

MIT Coal Study Overview

- Follow-on to *The Future of Nuclear Power*
 - On web at mit.edu/nuclearpower
- Full report to be released early 2007 (early March?)
- Authors
 - John Deutch, Ernie Moniz (PIs)
 - Jim Katzer (Executive Director)
 - Stephen Ansolabehere, Janos Beer, Denny Ellerman, Julio Friedmann, Howard Herzog, Jake Jacoby, Paul Joskow, Lester Richard, Greg McRae, Edward Steinfeld

Purpose of the Study

- Motivation
 - Concern that risk of adverse climate change from global warming is real
 - Governments are likely to adopt carbon mitigation policies that will restrict CO₂ emissions
- Objective
 - Describe the technical options that exist for coal use in the generation of electricity if carbon constraints are adopted
 - Describe the RD&D that should be underway today to have these technology options available in the future for rapid deployment
 - Does *not* evaluate or advocate carbon mitigation policies

Coal Today

- Relatively Cheap and Abundant
 - \$1-2/GJ vs. \$7-10/GJ for oil and gas
 - US, China, India, ...
- Significant Environmental Challenges
 - Mining and Transportation (only mentioned in study)
 - Criteria pollutants and mercury
 - CO₂ emissions

Carbon Capture and Storage

- CCS is the critical enabling technology that would reduce CO₂ emissions significantly while also allowing coal to meet the world's pressing energy needs.

Approaches to CO₂ Capture from Coal-Fired Power Plants

- Post-combustion
- Pre-combustion
- Oxyfuel Combustion

Pulverized Coal (PC) Power Plant

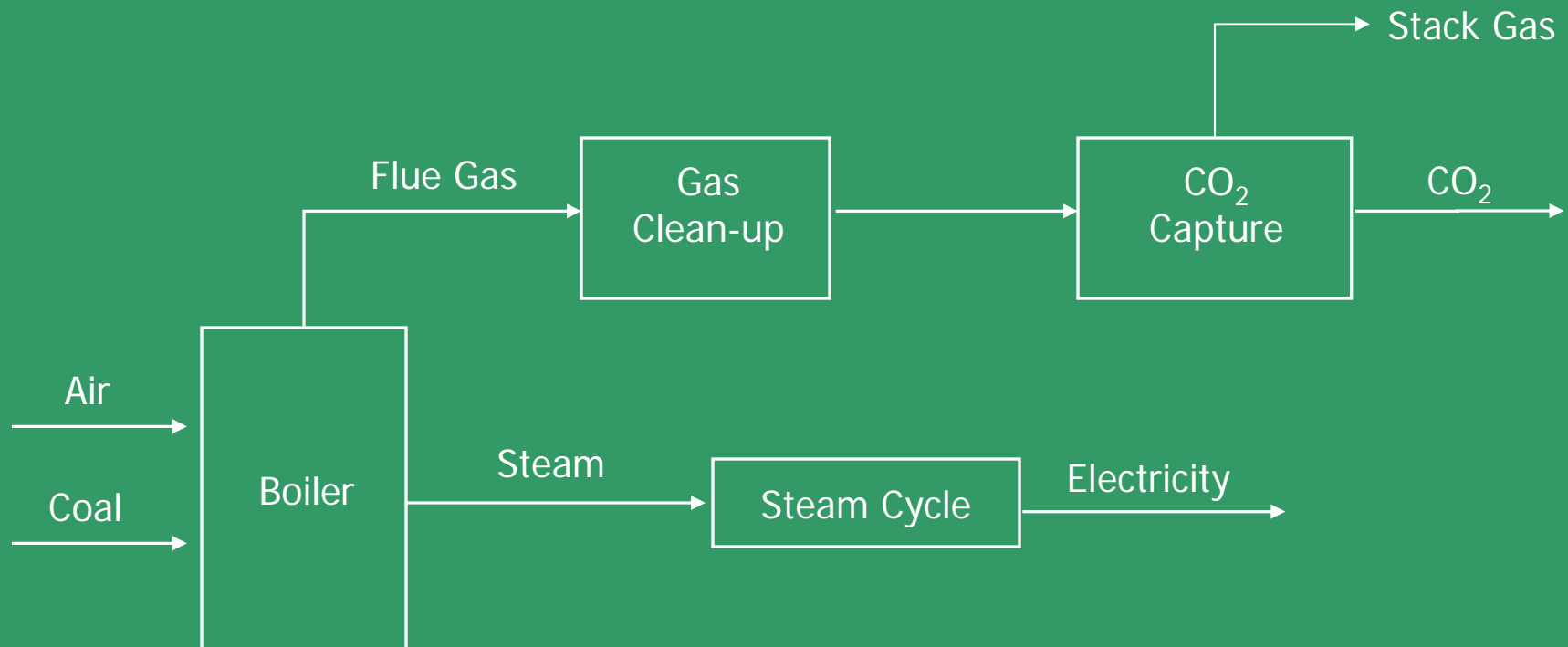

Schematic of Amine Process for CO₂ Capture

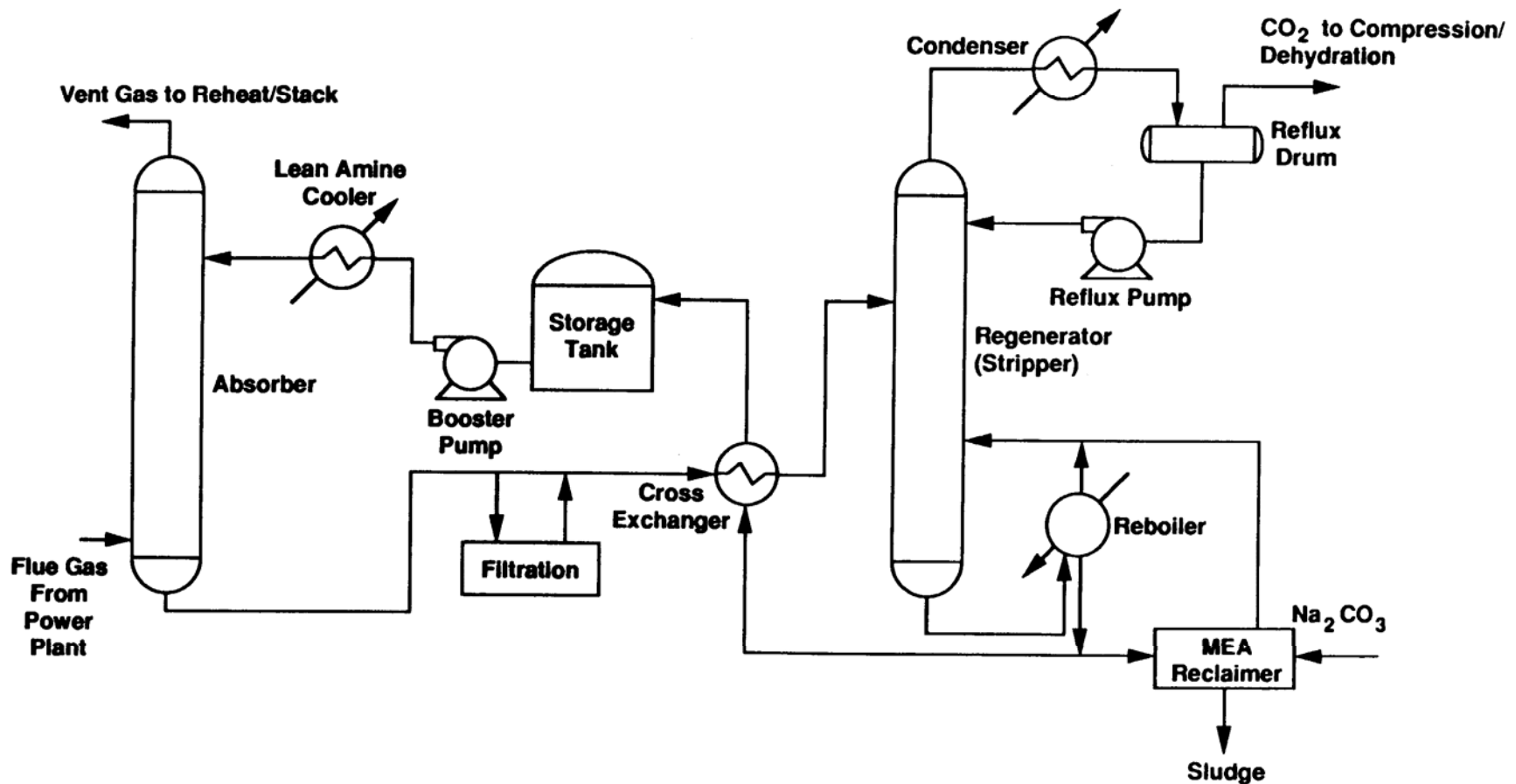

CO₂ Capture at a Coal-Fired Power Plant



Source: ABB Lummus

E.S. Rubin, Carnegie Mellon

Parasitic Energy Requirements for PC Plant with Amine Capture

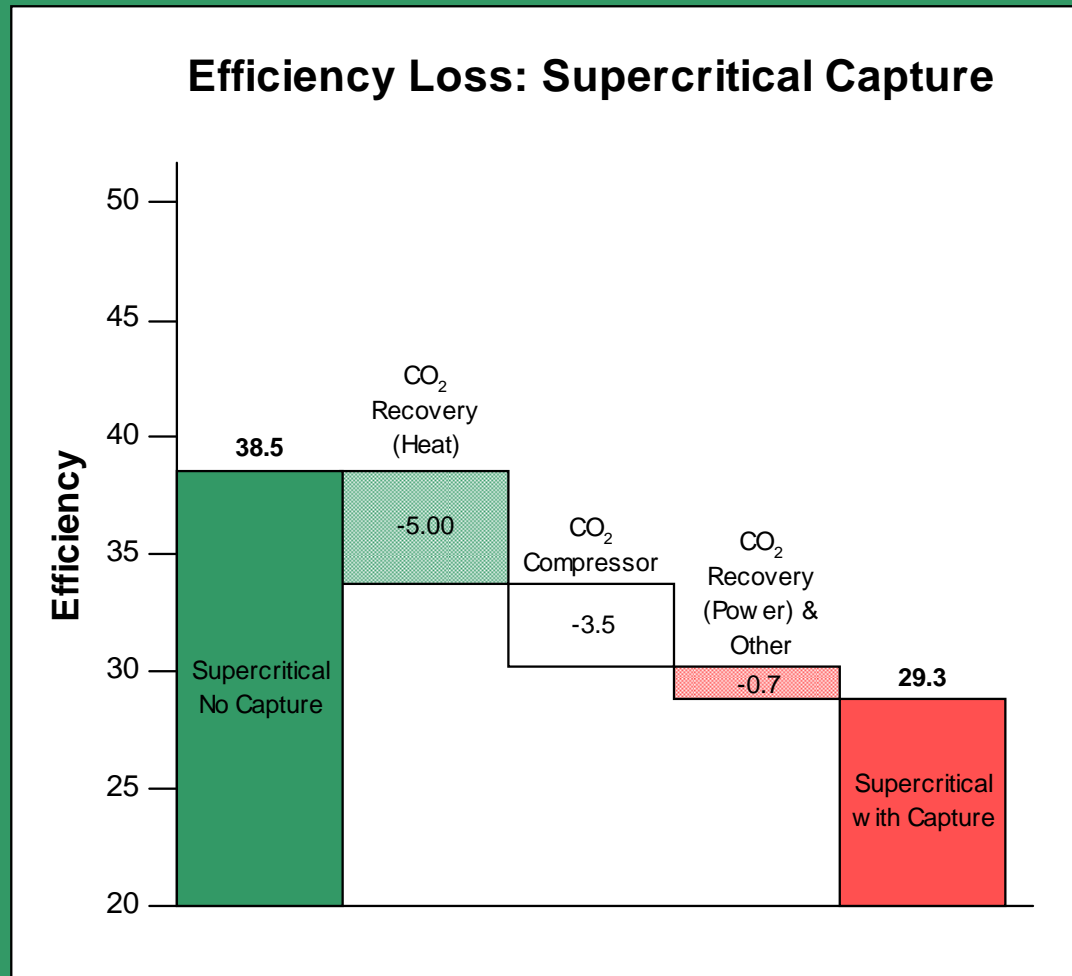

Change Power Generation Process to Facilitate CO₂ Capture

Power Plant	PC	IGCC	PC/Oxy
P (atm)	1	40	1
Fract CO ₂	0.15	0.40	0.9
PCO ₂ (atm)	0.15	16	0.9
Capture Process	Chemical Absorption	Physical Absorption	Distillation

IGCC Power Plant

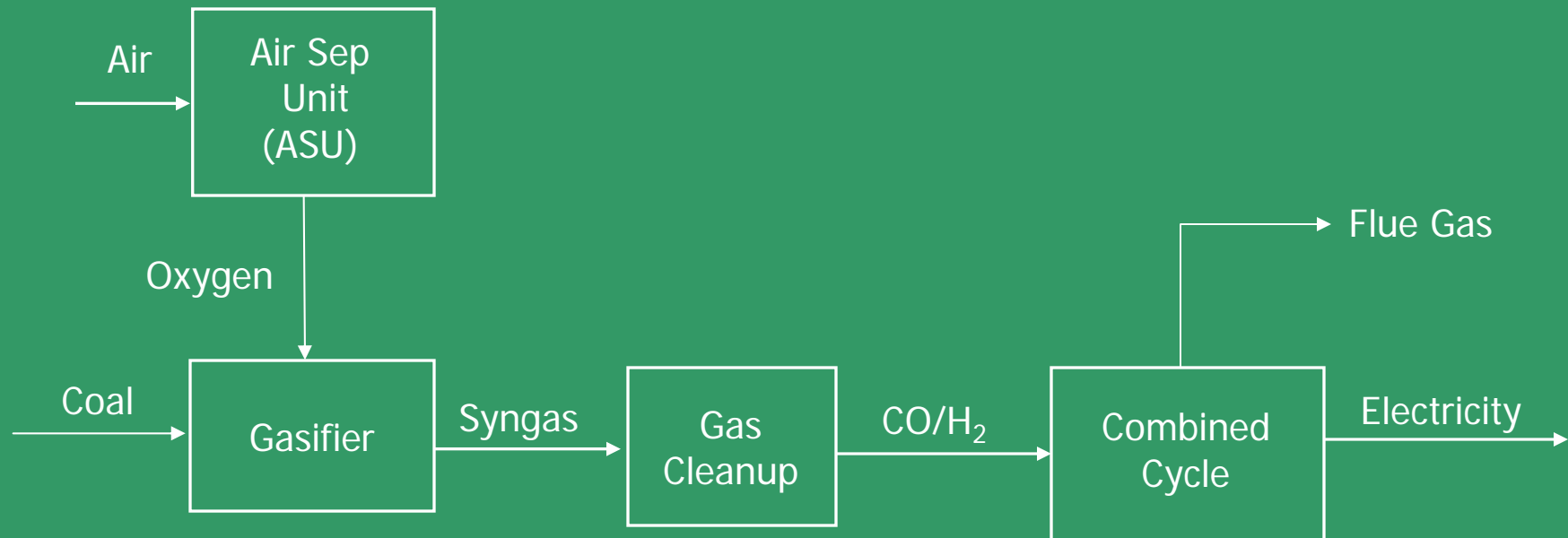

IGCC with Capture

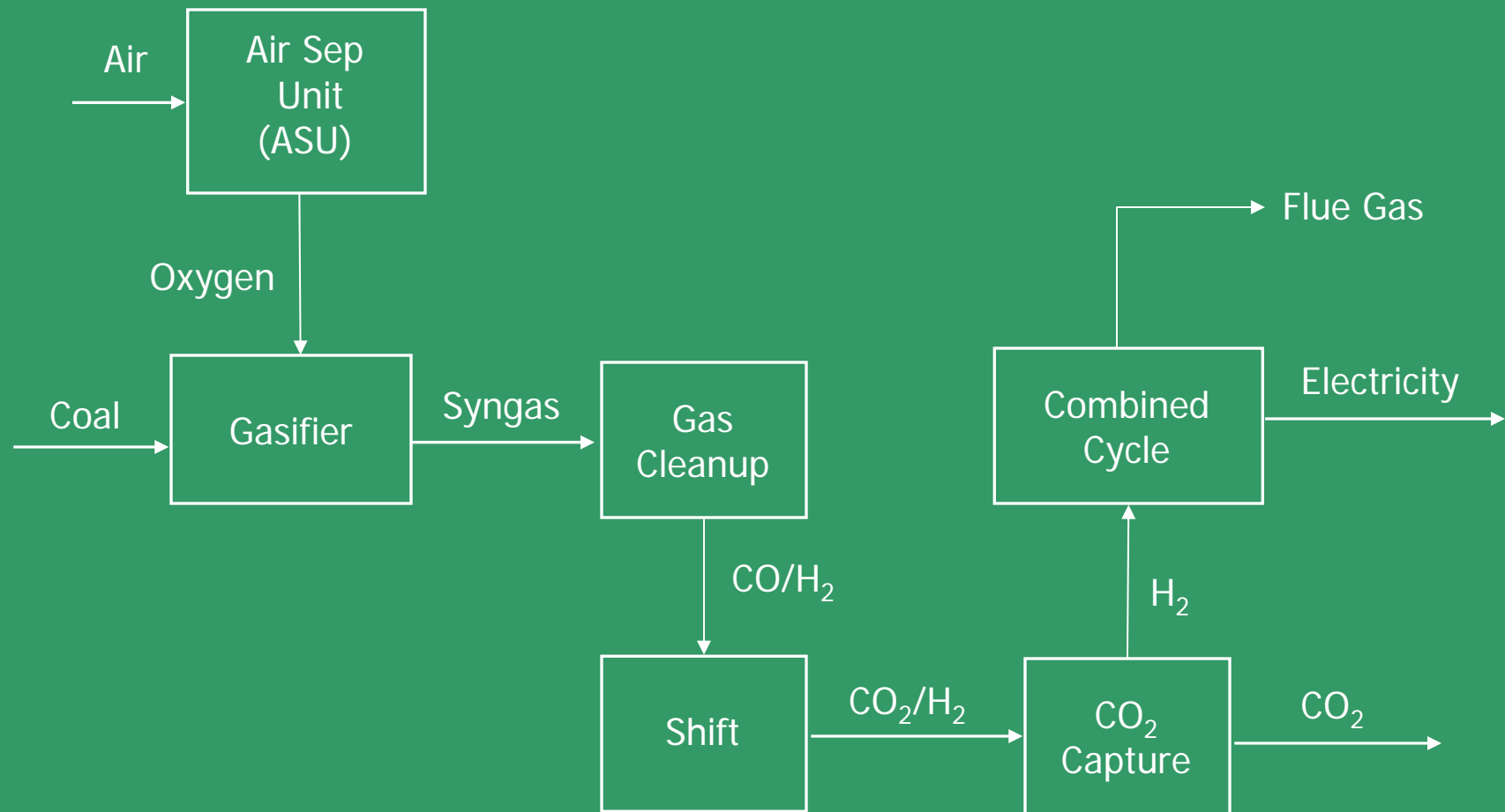

Parasitic Energy Requirements for IGCC with Capture

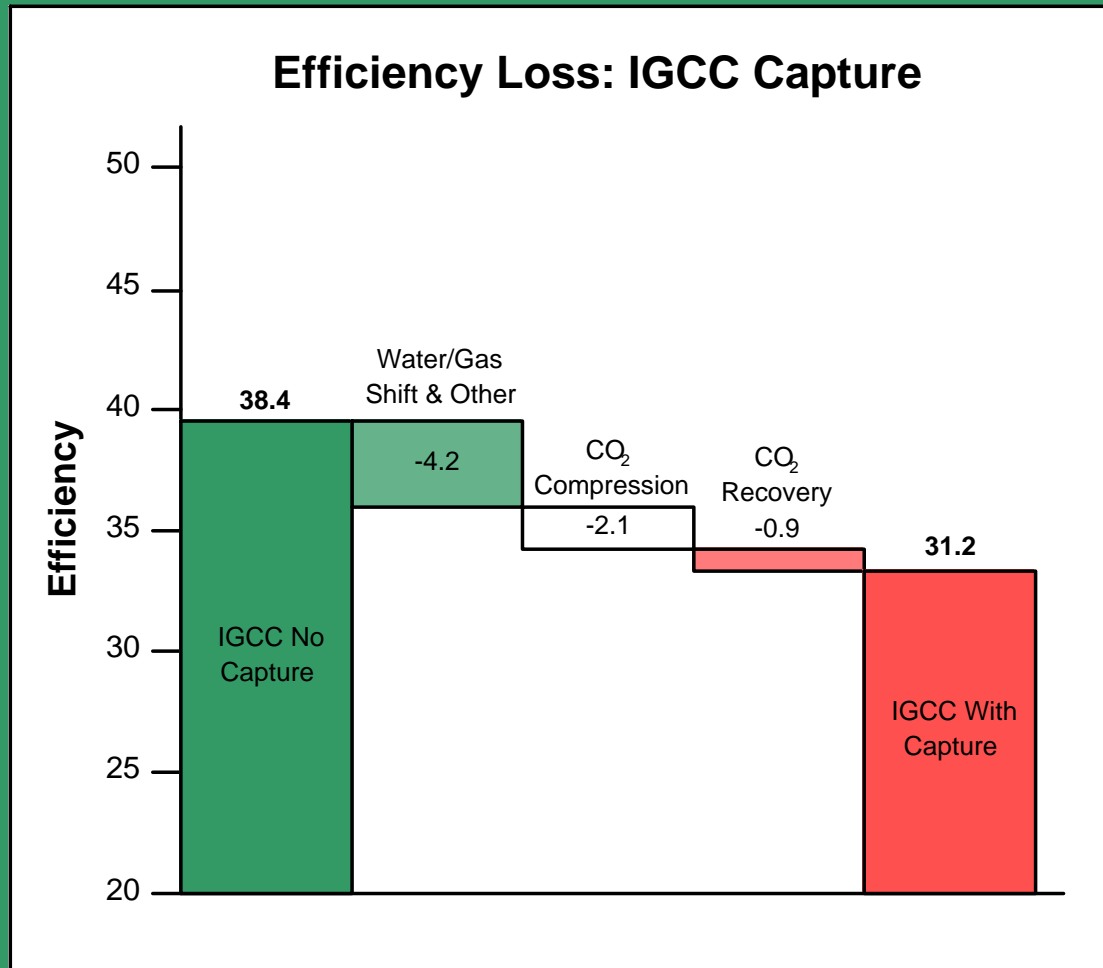

Oxyfuel Combustion Power Plant

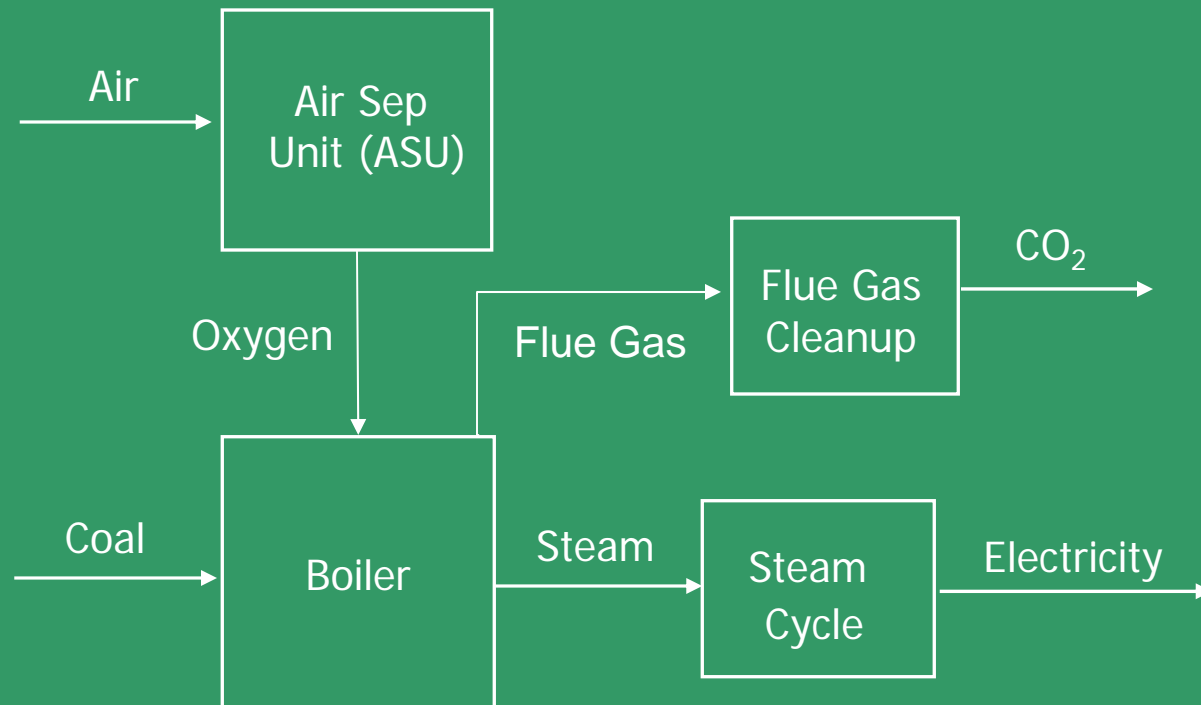

Parasitic Energy Requirements for Oxyfuel Capture

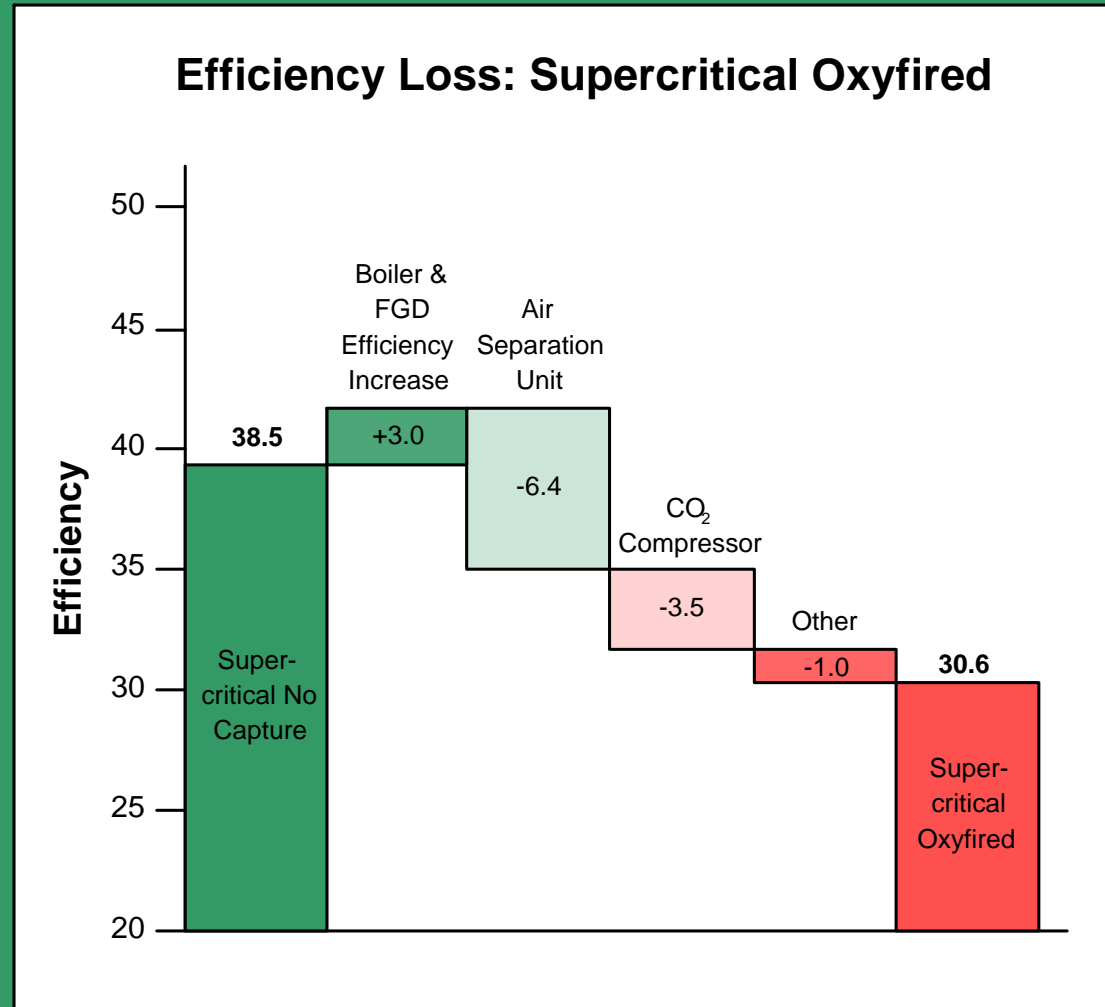

Capture and Compression Costs

- Output – high purity supercritical CO₂
- The numbers that follow are representative and are used to simply compare approaches
- There is much variability in the cost
 - Process Variability – plant location, coal type, criteria emission levels, process integration, etc.
 - Economic Variability – fuel costs, cost of capital, material and labor costs, capacity factor, etc.

Capture and Compression Capital Costs

Power Plant	Capture Technology	Capital Investment	Power Output	\$/kW
SCPC	Post-Combustion	+23%	-24%	+62%
SCPC	Oxyfuel-Combustion	+14%	-20%	+42%
IGCC	Pre-Combustion	+7%	-19%	+32%

Relative Cost of Electricity

	Without Capture	With Capture
Post-Combustion	1	1.61
Oxyfuel-Combustion		1.46
Pre-Combustion	1.07	1.36

Capture Finding Technology Choice

- It is premature to select one coal combustion technology as the preferred route for cost-effective electricity generation combined with CCS.

Relative Cost of Electricity

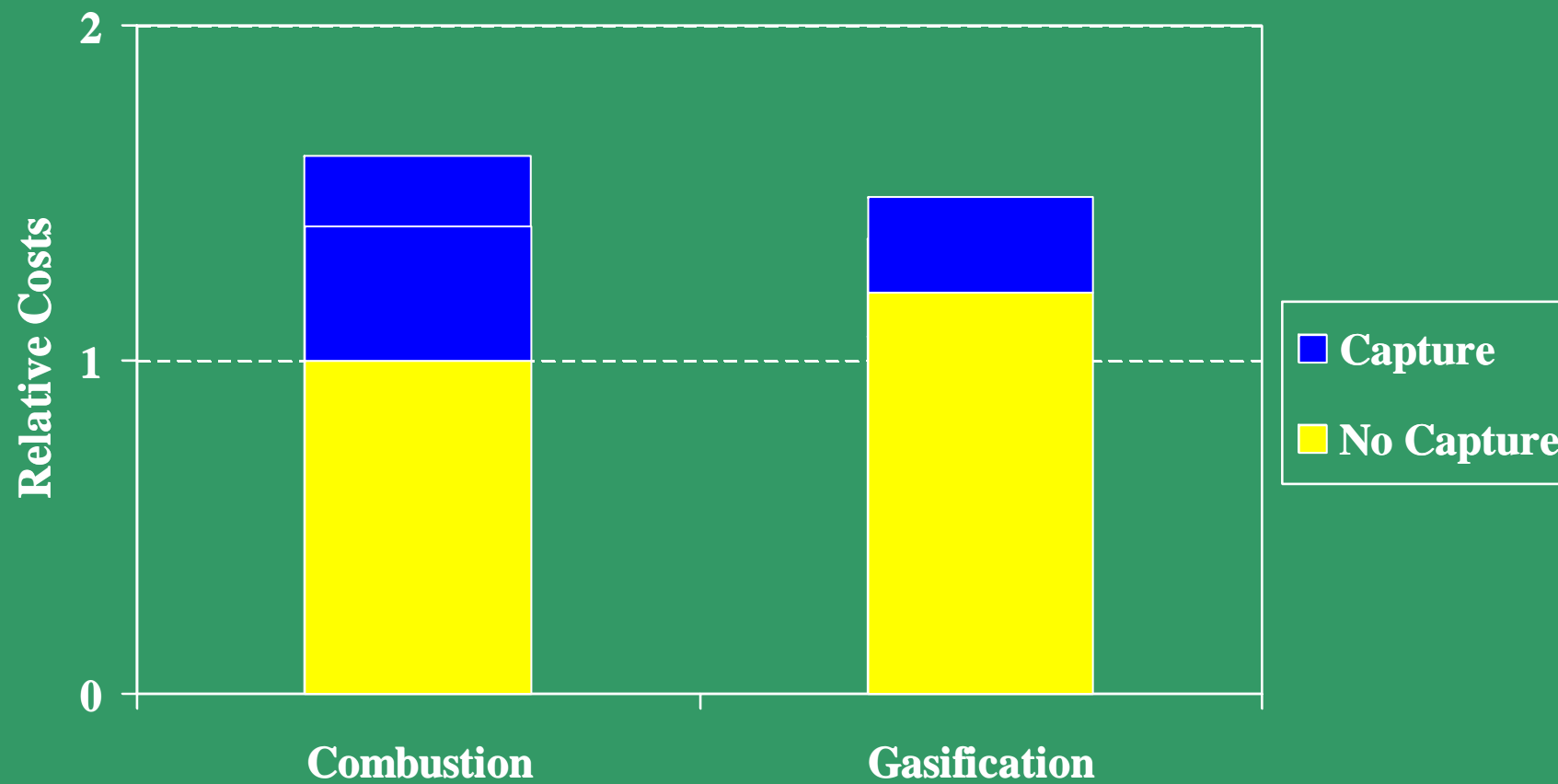

Retrofits

- MIT Coal Study – “Coal plants will not be cheap to retrofit for CO₂ capture.”
- Limitations at existing plants
 - Space
 - Storage site access
 - Efficiency
- Design of optimal “capture” plant differs from that of a “no capture” plant

Design considerations

Capture vs. no capture

- PC capture
 - Capture process
 - Compressor
 - Tighter SO₂ specs
 - Integration with LP turbine
 - High parasitic power requirement
- IGCC capture
 - Shift reactors
 - Capture process
 - Compressor
 - Quench design
 - Turbine design
 - Gasifier pressure
 - ASU/gasifier vs. turbine size
 - AGR sizing
 - ASU/Turbine integration
 - Moderate parasitic power requirement

MIT Coal Study Capture-Ready

- Other than a few low-cost measures such as providing for extra space on the plant site and considering the potential for geologic CO₂ storage in site selection, the opportunity to reduce the uncertain eventual cost of CCS retrofit by making preparatory investment in plants without CO₂ capture does not look promising.

CO₂ Transport



- There exists an extensive network of CO₂ pipeline stretching nearly 2000 miles in the United States

National CO₂ Network

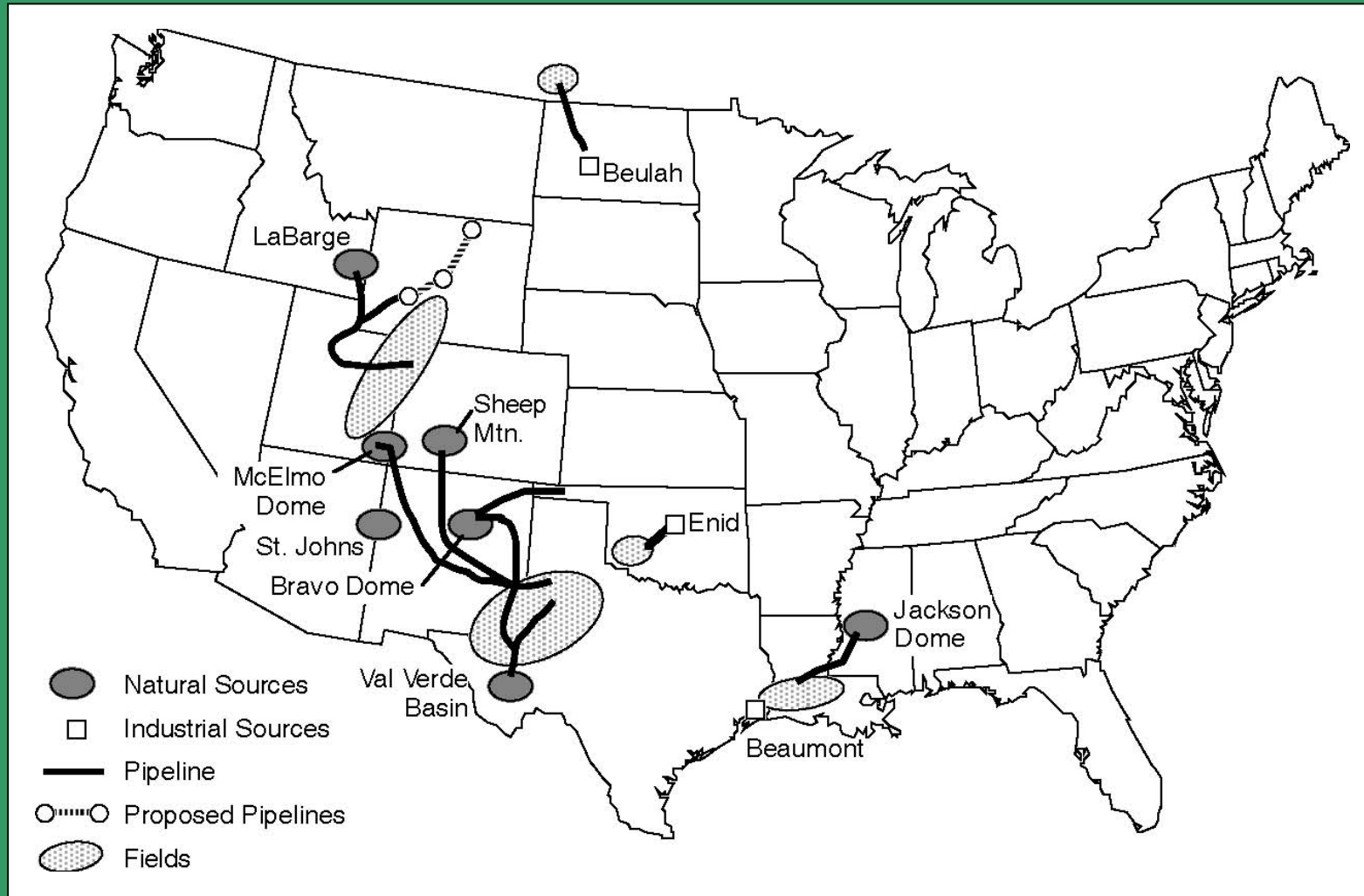

Transport Costs

- Restrict discussion to pipelines
- Process Variability
 - Length of the pipe
 - Location and terrain
 - Scale

Cost of CO₂ Pipeline Transport

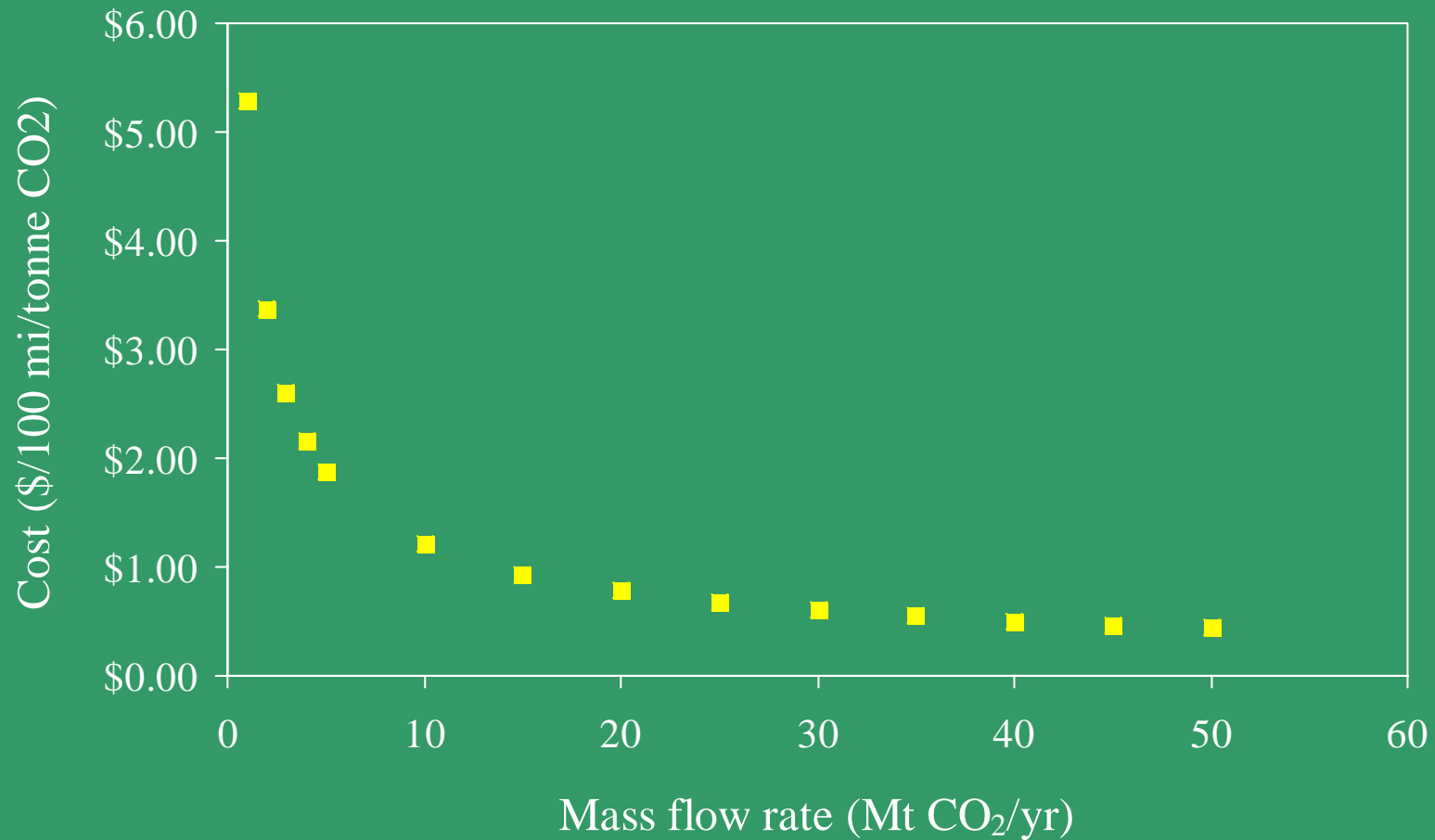

Land Construction Costs of Natural Gas Pipeline (1989-1998) versus Pipe Diameter

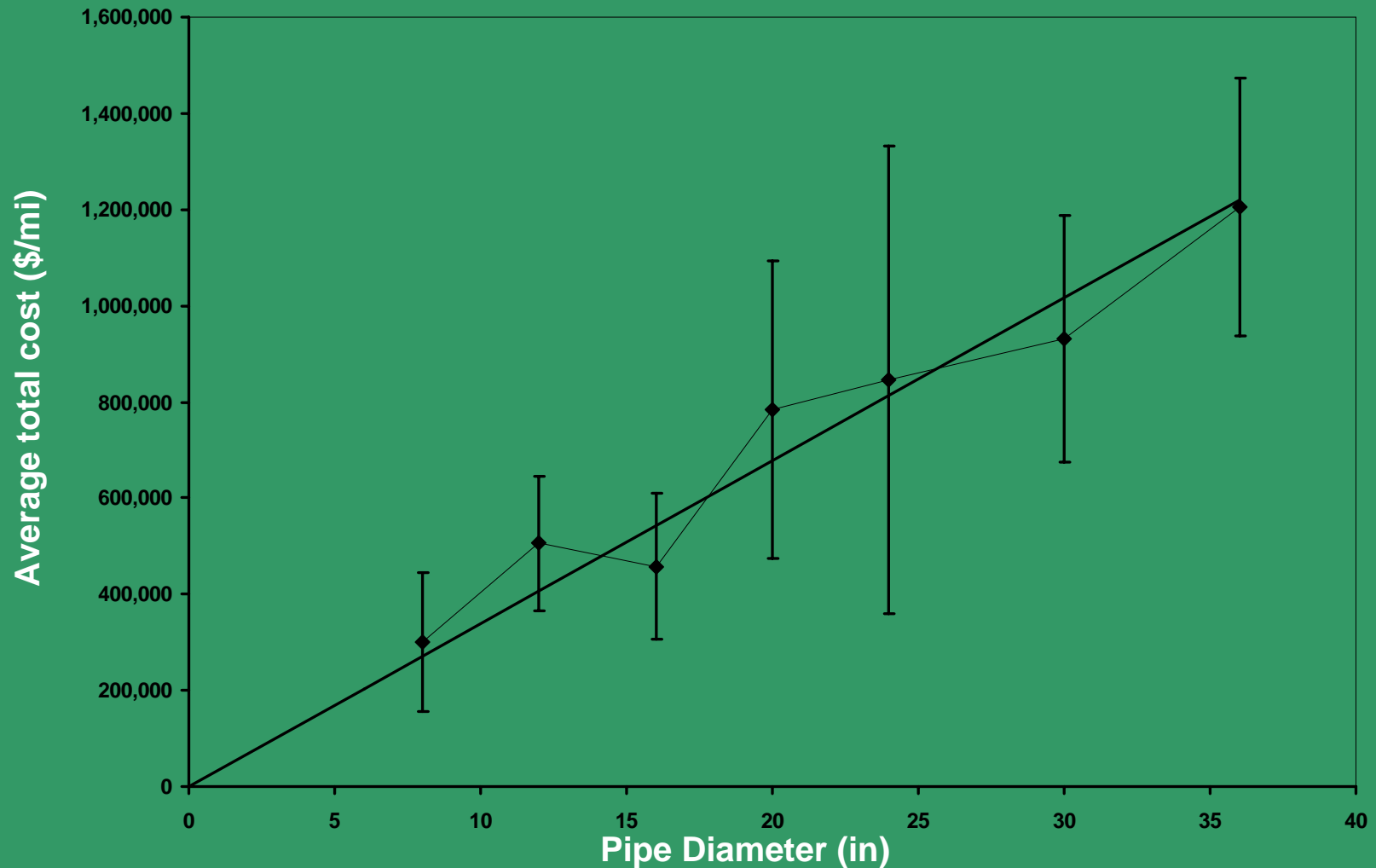

Howard Herzog / MIT Laboratory for Energy and the Environment

Injection Costs

Process Variability

- Type of Reservoir
- Reservoir Properties
 - Porosity
 - Depth
 - Pressure
 - Permeability
 - Thickness
 - Volume
- Seal Characteristics

Cost of CO₂ Transport and Injection

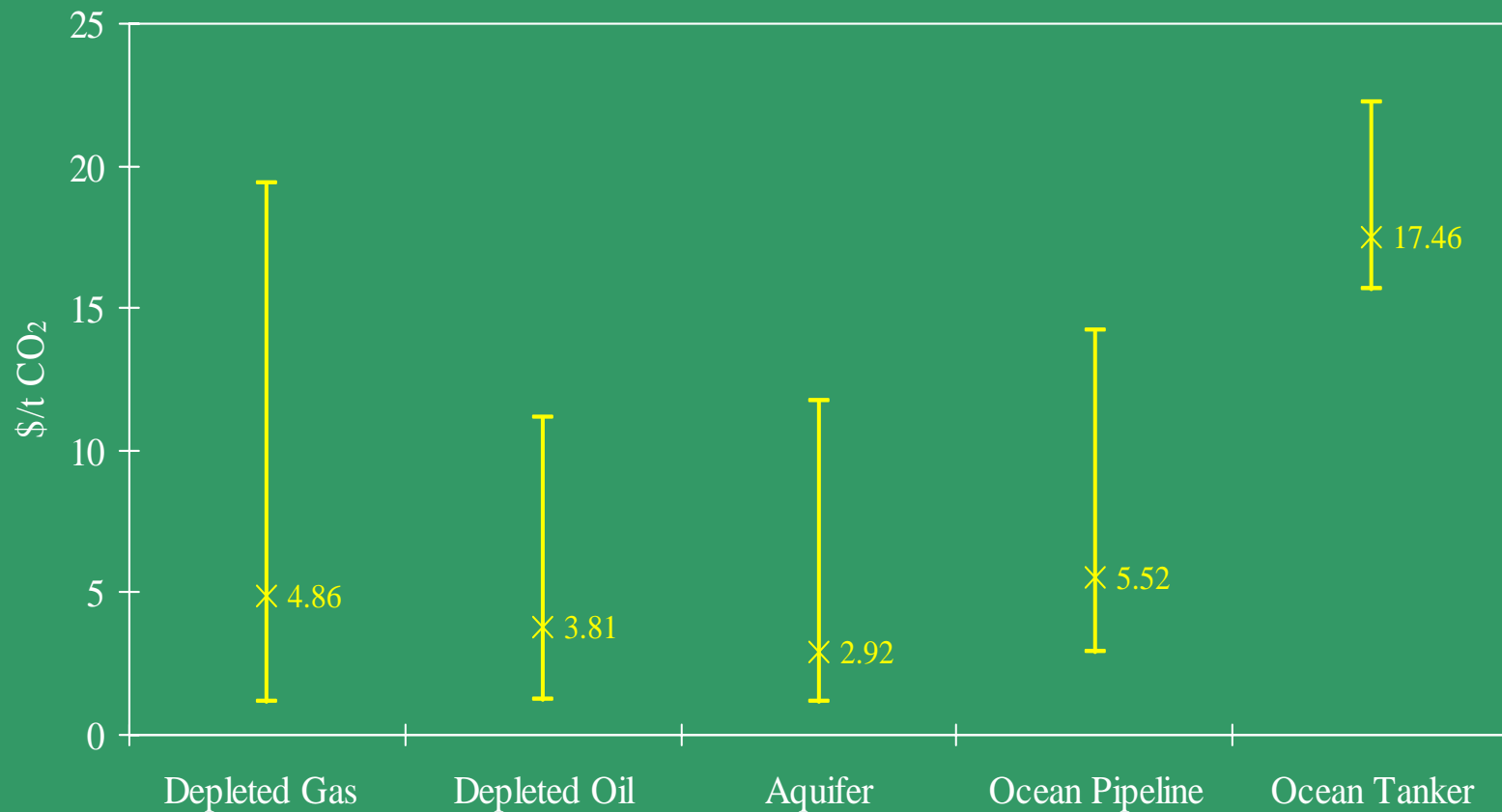

Mitigation Costs for CCS

Type of Capture Plant	Cost (\$/tCO ₂ avoided)
Post-combustion Supercritical PC	45
Oxyfuel Supercritical PC	35
Pre-Combustion IGCC	29

Assumptions:

- Base case is Supercritical PC
- Uses technology available today
- Assumes an nth plant (versus 1st of a kind)
- Transport/storage cost is \$5/tCO₂

CCS Economics

- Successful implementation of CCS will inevitably add cost for coal combustion and conversion. We estimate that for new plant construction, a CO₂ emission price of approximately \$30/tonne (about \$110/tonne C) would make CCS cost competitive with coal combustion and conversion systems without CCS. This estimate of CCS cost is uncertain; it might be larger or with new technology, perhaps smaller.

MIT Coal Study Figure 2.4

Global Primary Energy Consumption under High CO₂ Prices

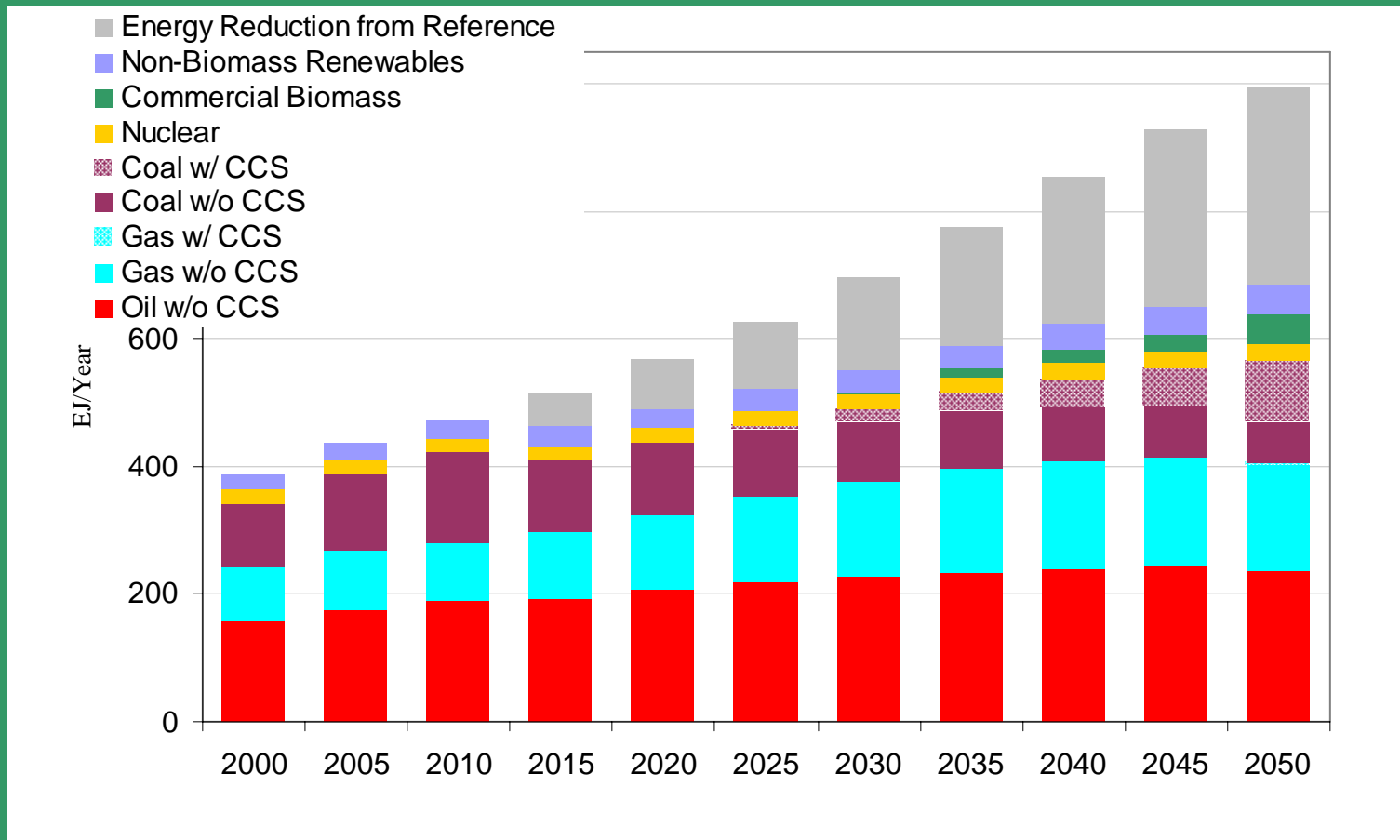

Proposed Large-Scale CCS Projects

Project	Country	Type
Monash	Australia	Fuel
ZeroGen	Australia	Power
Gorgon	Australia	Gas Proc
SaskPower	Canada	Power
Greengen	China	Power
nZEC	China	Power
Vattenfall	Germany	Power
RWE	Germany	Power
Draugen	Norway	Power

Project	Country	Type
Mongstad	Norway	Power
Snovit	Norway	Gas Proc
BP Peterhead	UK	Power
E.On	UK	Power
RWE npower	UK	Power (retrofit)
Progressive	UK	Power
Powerfuel	UK	Power
FutureGen	USA	Power
BP Carson	USA	Power

Carbon Prices – EU Trading System

Market Price of EU Allowances in €/t, 2006-07

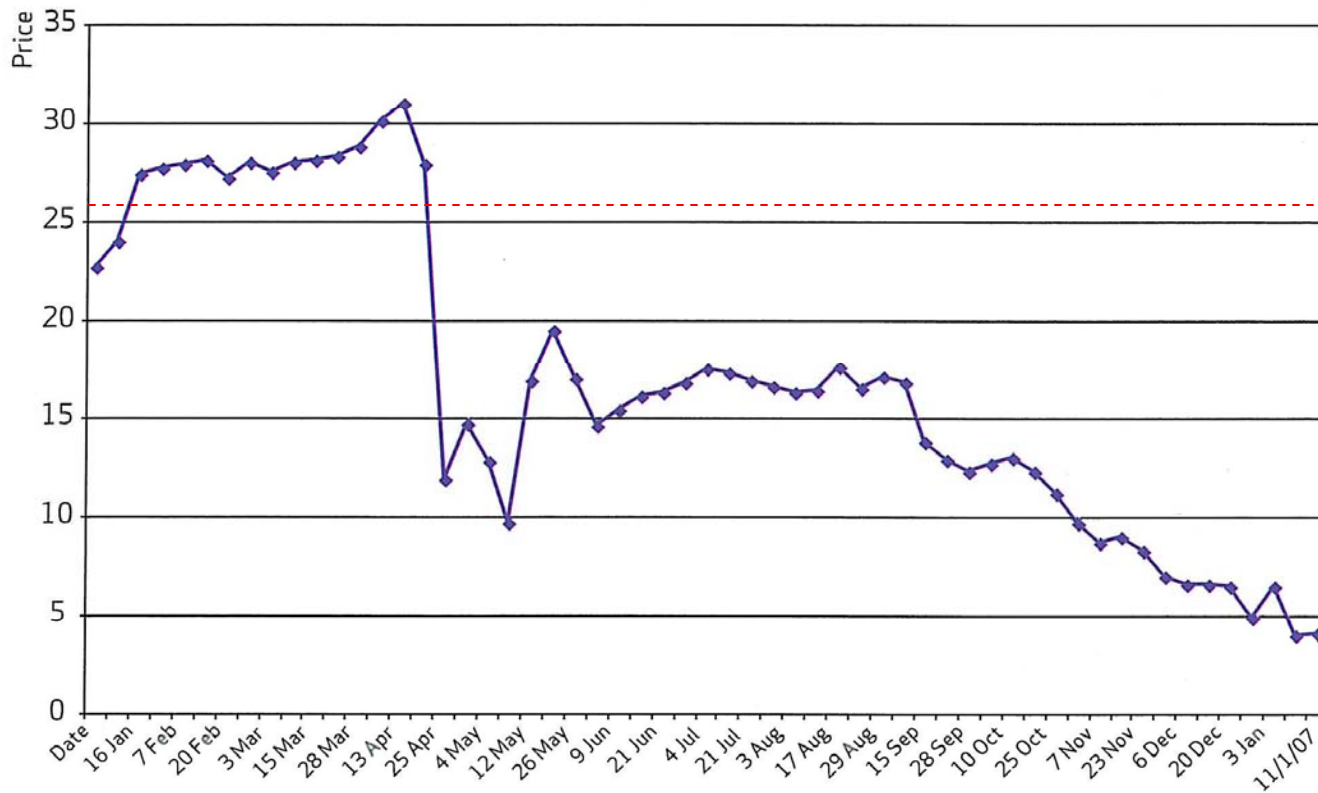

Source: Point Carbon

CCS Outlook

- Until policy creates a “price” for CO₂ emissions, implementation limited.
- Even with a sufficient CO₂ price, there are outstanding questions about CCS implementation at scale that need to be addressed – we should start addressing those questions immediately

Contact Information

- Web Site - sequestration.mit.edu
- Contact
 - Howard Herzog
 - Laboratory for Energy and the Environment (LFEE)
 - Room E40-447
 - 617-253-0688
 - hjherzog@mit.edu